

TA Instruments

109 Lukens Drive New Castle, DE 19720

Thermal Analysis & Rheology

A SUBSIDIARY OF WATERS CORPORATION

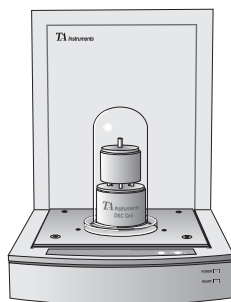

DSC 2010

Differential Scanning Calorimeter

Operator's Manual

PN 925604.001 Rev. E (Text and Binder)

PN 925604.002 Rev. E (Text Only)

Issued May 1998

©1995, 1996, 1997, 1998 by TA Instruments
109 Lukens Drive
New Castle, DE 19720

Notice

The material contained in this manual is believed adequate for the intended use of this instrument. If the instrument or procedures are used for purposes other than those specified herein, confirmation of their suitability must be obtained from TA Instruments. Otherwise, TA Instruments does not guarantee any results and assumes no obligation or liability. This publication is not a license to operate under or a recommendation to infringe upon any process patents.

TA Instruments Operating Software and Instrument, Data Analysis, and Utility Software and their associated manuals are proprietary and copyrighted by TA Instruments, Inc. Purchasers are granted a license to use these software programs on the instrument and controller with which they were purchased. These programs may not be duplicated by the purchaser without the prior written consent of TA Instruments. Each licensed program shall remain the exclusive property of TA Instruments, and no rights or licenses are granted to the purchaser other than as specified above.

Table of Contents

Notes, Cautions, and Warnings	<i>ix</i>
Safety	<i>x</i>
Using This Manual	<i>xv</i>
CHAPTER 1: Introducing the DSC 2010	1-1
Introduction	1-3
Components	1-5
The 2010 Instrument	1-6
2010 Instrument Keypad	1-7
POWER Switch	1-9
2010 DSC Cell	1-9
Accessories	1-10
Sample Encapsulating Press	1-10
Accessories for Subambient Operation	1-11
LNCA	1-11
RCS	1-12
DSC Cooling Can	1-13
Specifications	1-14

Table of Contents

(continued)

CHAPTER 2: Installing the DSC 2010	2-1
Unpacking/Repacking the 2010	2-3
Unpacking the 2010	2-3
Unpacking the DSC Cell	2-6
Repacking the 2010	2-6
Installing the 2010 Instrument	2-7
Inspecting the System	2-7
Choosing a Location	2-8
Connecting Cables and Gas Lines	2-9
GPIB Cable	2-9
Purge, Vacuum, and Cooling Gas Lines	2-12
PURGE Line	2-12
VACUUM Line	2-13
COOLING GAS Line	2-13
Power Cable	2-15
Installations for Subambient Operation ...	2-16
Installing the DSC Cooling Can	2-17
Starting the 2010	2-20
Shutting Down the 2010	2-21

Table of Contents

(continued)

CHAPTER 3: Running Experiments	3-1
Overview	3-3
Before You Begin	3-3
Calibrating the DSC	3-4
Baseline Slope and Offset Calibration	3-5
Cell Constant Calibration	3-6
Temperature Calibration	3-6
Running a DSC Experiment	3-7
Experimental Procedure	3-7
Preparing Samples	3-8
Determining Sample Size	3-8
Physical Characteristics	3-9
Selecting Sample Pans	3-9
Sample Pan Material	3-9
Sample Pan Configuration	3-11
Nonhermetic Pans	3-11
Hermetic Pans	3-11
Open Pans	3-12
SFI Pans	3-12
Encapsulating the Sample	3-12
Preparing Nonhermetic Sample Pans	3-13
Preparing Hermetic Sample Pans	3-16
Setting Up Accessories	3-19
Loading the Sample	3-21

Table of Contents

(continued)

Starting an Experiment	3-23
Stopping an Experiment	3-23
Subambient Experiments	3-24
DSC Cooling Can	3-24
Applications	3-24
Operation	3-25
Quench-Cooling Between Runs	3-25
Starting a Run Below Ambient Temperature	3-26
Programmed Cooling	3-26
CHAPTER 4: Technical Reference	4-1
Description of the DSC 2010	4-3
DSC Cell	4-3
Principles of Operation	4-5
Cell Block Heating	4-5
Sample and Reference Thermocouples ...	4-6
DSC Applications	4-7
Sample Types	4-7
Status Codes	4-8

Table of Contents

(continued)

Guidelines for Quantitative Studies	4-12
Specific Heat Experiments	4-12
CHAPTER 5: Maintenance and Diagnostics	5-1
Overview	5-3
Routine Maintenance	5-4
Inspection	5-4
Cleaning the Instrument Keypad	5-4
Cleaning a Contaminated Cell	5-4
Cleaning DSC Pans	5-5
Sample Encapsulating Press	5-7
Diagnosing Power Problems	5-8
Fuses	5-8
Power Failures	5-9
DSC 2010 Test Functions	5-12
2010 Confidence Test	5-12
Replacement Parts	5-13

Table of Contents

(continued)

**Appendix A: Sample
Encapsulating Press..... A-1**

**Appendix B: Ordering
Information B-1**

Index..... I-1

Notes, Cautions, and Warnings

This manual uses NOTES, CAUTIONS, and WARNINGS to emphasize important and critical instructions.

NOTE:

|| A NOTE highlights important information about equipment or procedures.

◆ **CAUTION:**

|| A CAUTION emphasizes a procedure that may damage equipment or cause loss of data if not followed correctly.



|| A WARNING indicates a procedure that may be hazardous to the operator or to the environment if not followed correctly.

Safety

This equipment has been designed to comply with the following standards on safety:

- IEC 1010-1/1990 and A1/1992
- IEC 1010-2-010/1992
- EN 61010-1/1992
- EN 61010-2-010/1994
- UL 3101-1, First Edition.

Electrical Safety

You must unplug the instrument before doing any maintenance or repair work; voltages exceeding 110 volts AC are present in this system.



High voltages are present in this instrument. If you are not trained in electrical procedures, do not remove the cabinet covers. Maintenance and repair of internal parts must be performed only by TA Instruments or other qualified service personnel.



After transport or storage in humid conditions, this equipment could fail to meet all the safety requirements of the safety standards indicated. Refer to the NOTE on page 2-8 for the method used to dry out the equipment before use.



WARNING

Potential Asphyxiant

Liquid nitrogen can cause rapid suffocation without warning.

Store and use in an area with adequate ventilation.

Do not vent LNCA container in confined spaces.

Do not enter confined spaces where nitrogen gas may be present unless the area is well ventilated.

The warning above applies to the use of liquid nitrogen. Oxygen depletion sensors are sometimes utilized where liquid nitrogen is in use. Please refer to the "Safety" section of the *TA Instruments Liquid Nitrogen Cooling Accessory* manual for more detailed instructions regarding the use of the LNCA.

Safety

(continued)

Handling Liquid Nitrogen

The DSC 2010 uses the cryogenic (low-temperature) agent, liquid nitrogen, for cooling. Because of its low temperature (-195°C), liquid nitrogen will burn the skin. When you work with liquid nitrogen, use the following precautions:



Liquid nitrogen evaporates rapidly at room temperature. Be certain that areas where liquid nitrogen is used are well ventilated to prevent displacement of oxygen in the air.

1. Wear goggles or a face shield, gloves large enough to be removed easily, and a rubber apron. For extra protection, wear high-topped, sturdy shoes, and leave your pant legs outside the tops.
2. Transfer the liquid slowly to prevent thermal shock. Use containers that have satisfactory low-temperature properties. Ensure that closed containers have vents to relieve pressure.
3. The purity of liquid nitrogen decreases as the nitrogen evaporates. If much of the liquid in a container has evaporated, analyze the remaining liquid before using it for any purpose where high oxygen content could be dangerous.

Safety

(continued)

IF A PERSON IS BURNED BY LIQUID NITROGEN ...

1. IMMEDIATELY flood the area (skin or eyes) with large quantities of cool water, and then apply cold compresses.
2. If the skin is blistered or if there is a chance of eye infection, take the person to a doctor IMMEDIATELY.

Chemical Safety



Do not use hydrogen or any other explosive gas with the DSC 2010.

◆ **CAUTION:**

Use of chlorine gas will damage the cell.



Some samples may give off hazardous gases when heated. Make sure that the DSC 2010 is well ventilated. Use a laboratory hood or exhaust hose to ventilate gases.

Thermal Safety

After running an experiment, you must allow the DSC Cell to cool down before you touch the internal cell surfaces. These surfaces can be hot enough to burn the skin during a sample run.

Safety

(continued)

Lifting the Instrument

The DSC 2010 is a fairly heavy instrument. In order to avoid injury, particularly to the back, please follow this advice:



Use two people to lift and/or carry the instrument. The instrument is too heavy for one person to handle safely.

Using This Manual

Chapter 1	Describes the 2010 instrument and its specifications.
Chapter 2	Describes how to connect the 2010 instrument to the rest of your system.
Chapter 3	Describes how to run DSC experiments.
Chapter 4	Provides technical information and explains the DSC principles of operation.
Chapter 5	Describes instrument maintenance procedures and lists replacement parts.
Appendix A	Explains how to change the Sample Encapsulating Press dies.
Appendix B	Lists worldwide TA Instruments offices that you can contact to place orders, receive technical assistance, and request service.
Index	Lists the page numbers of important topics for your reference.



CHAPTER 1: Introducing the DSC 2010

Introduction	1-3
Components	1-5
The 2010 Instrument	1-6
2010 Instrument Keypad	1-7
POWER Switch	1-9
2010 DSC Cell	1-9
Accessories	1-10
Sample Encapsulating Press	1-10
Accessories for Subambient Operation	1-11
LNCA	1-11
RCS	1-12
DSC Cooling Can	1-13
Specifications	1-14

Introducing the DSC 2010

Introduction

The Differential Scanning Calorimeter (DSC) 2010 (Figure 1.1) determines the temperature and heat flow associated with material transitions as a function of time and temperature. It also provides quantitative and qualitative data on endothermic (heat absorption) and exothermic (heat evolution) processes of materials during physical transitions that are caused by phase changes, melting, oxidation, and other heat-related changes. This information helps the scientist or engineer identify processing and end-use performance.

The DSC 2010 instrument works in conjunction with a controller and associated software to make up a thermal analysis system.

Your controller is a computer that performs the following functions:

- Provides an interface between you and the analysis instrument
- Enables you to set up experiments and enter constants
- Stores experimental data
- Runs data analysis programs.

Introducing the DSC 2010

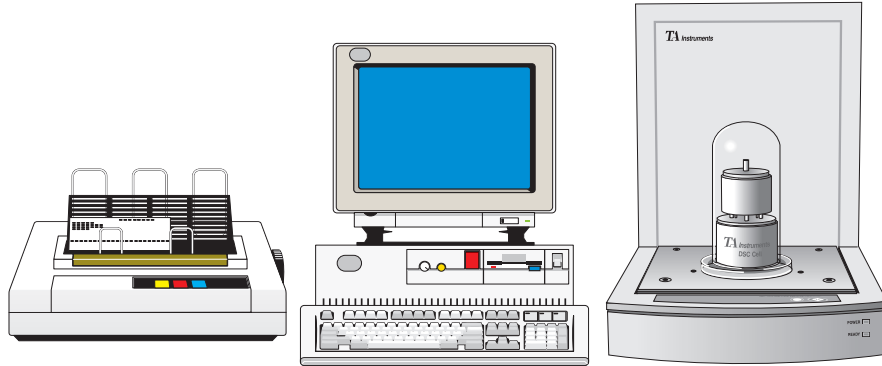

Figure 1.1
DSC 2010 with
TA Instruments
Thermal Analyzer

Components

The DSC 2010 (see Figure 1.2) has two major parts: the 2010 instrument, which contains the system electronics, and the cell, which contains its own thermocouples (temperature sensors) for monitoring differential heat flow and temperatures. The 2010 DSC cell is not interchangeable with other cells or cell types. However, if necessary, the cell can be replaced by qualified service personnel.

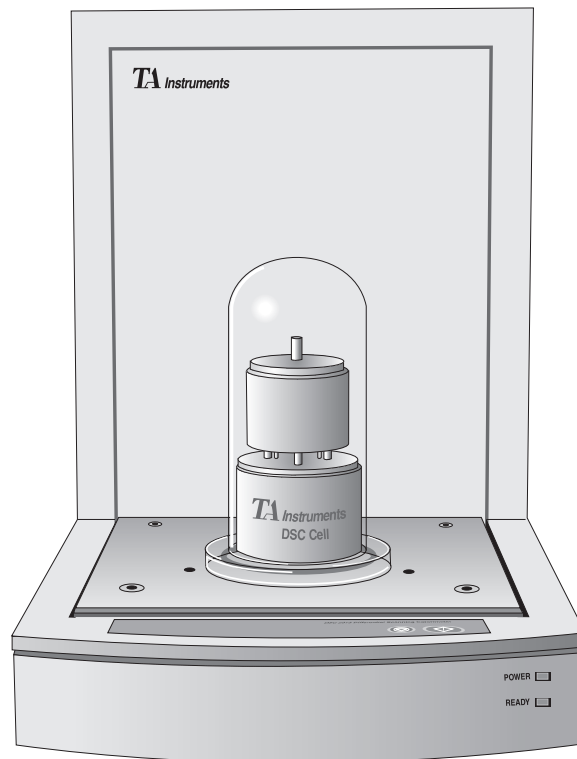

Figure 1.2
DSC 2010

The 2010 Instrument

The 2010 instrument contains the electronics and software needed to perform experiments and store experimental results. The battery backed-up RAM in the instrument saves parameters vital to system operations if power is interrupted. Also contained in the instrument is a GPIB interface for communication with the controller.

The keypad on the front of the 2010 instrument enables you to start and stop experiments.

The 2010 instrument also contains several hook-ups for other components and accessories in the thermal analysis system, including:

- Gas purge line
- Cooling gas line
- Vacuum line
- LNCA (Liquid Nitrogen Cooling Accessory)
- Gas Switching Accessory
- EVENT switch
- GPIB (General Purpose Interface Bus)
- Power cable.

2010 Instrument Keypad

The instrument keypad (see Figure 1.3) contains keys that control local operations at the instrument.

NOTE:

Experiment information and instrument constants are entered from the controller keyboard, not the instrument keypad.

Table 1.1 explains the functions of the instrument keys.

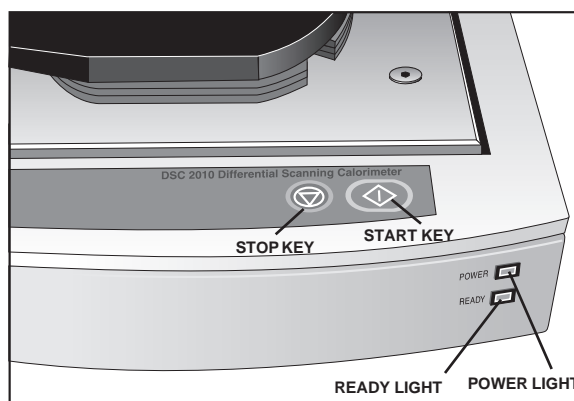

Figure 1.3
2010 DSC
Instrument Keypad

Table 1.1
2010 Instrument
Keypad Function Keys

Key/Function	Explanation
START	Initiates the experiment after checking the method and the cell. This is the same function as Start on the controller.
STOP	<p>If an experiment is running, this key ends the method normally, as though it had run to completion; <i>i.e.</i>, the method-end conditions selected go into effect, and the data that has been generated is <i>saved</i>. This is the same function as Stop on the controller.</p> <p>If an experiment is not running (the instrument is in a stand-by or method-end state), the STOP key halts any activity (air cool, LNCA auto-fill, <i>etc.</i>).</p>

POWER Switch

The POWER switch on the back of the instrument turns the power to 2010 instrument on and off. The green power light on the front panel shows that the instrument is ON. The yellow light shows when the instrument is ready.

2010 DSC Cell

The 2010 DSC cell (Figure 1.4) is used to measure differential heat flow. The sample and a reference are materials placed in pans that sit on raised platforms on a constantan disc, and heat is transferred through the disc up into the sample and reference. The differential heat flow is monitored by thermocouples beneath the disc.

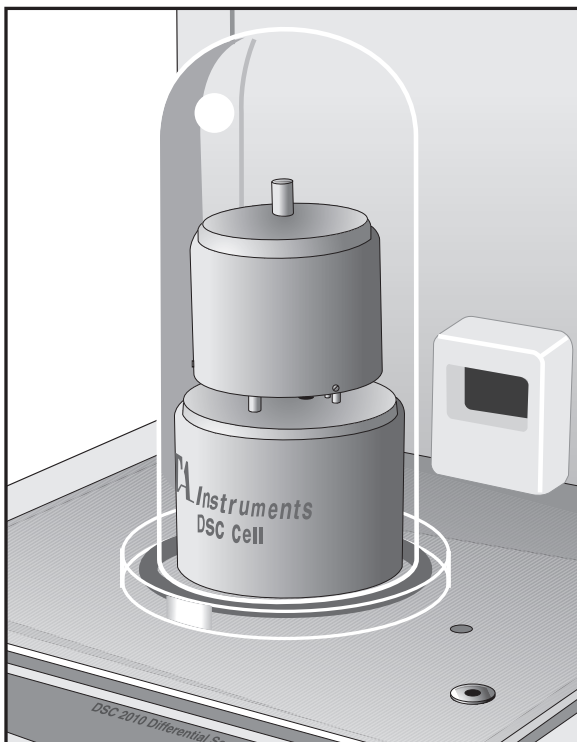

Figure 1.4
2010 DSC Cell

Accessories

Sample Encapsulating Press

The TA Instruments Sample Encapsulating Press (Figure 1.5) is used to prepare encapsulated samples for DSC experiments. It comes with two sets of dies, one for hermetic and one for nonhermetic sealing.

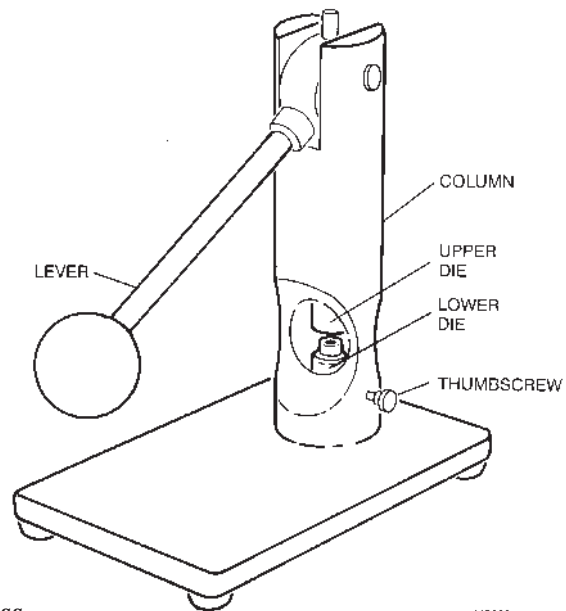

Figure 1.5
Sample Encapsulating Press

A136854 64

Accessories for Subambient Operation

The DSC 2010 can be operated at below-ambient temperatures using one of three accessories: the Liquid Nitrogen Cooling Accessory (LNCA), the Refrigerated Cooling System (RCS), or the DSC Cooling Can.

LNCA

The LNCA (Figure 1.6) achieves automatic and continuous programmed sample cooling within the range of -150°C to 725°C when used with the DSC Heat Exchanger installed on the DSC Cell (refer to Chapter 2 for installation). Heaters vaporize the liquid nitrogen in the LNCA tank, and then the vapor collects and passes through a U-shaped tube to the bottom of the tank, where it is cooled by the surrounding liquid. The cooled gas is forced up and mixed with liquid nitrogen. The gas/liquid mix is delivered to the Heat Exchanger to cool the cell.

You can easily gain access to your samples with the LNCA by simply removing the lids on the DSC Heat Exchanger.

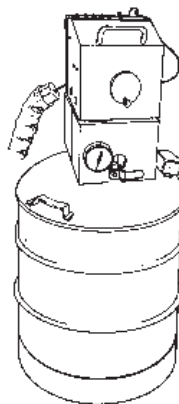

Figure 1.6
LNCA

Refrigerated Cooling System (RCS)

The Refrigerated Cooling System (RCS), which is used to cool DSC experiments, consists of a two-stage, cascade, vapor compression refrigeration system with an attached cooling head. The cooling head fits over the RCS-DSC cell for use with the DSC 2010. The RCS can be used for experiments requiring cooling within an operating range of -70°C to 400°C . The maximum rate of cooling depends on the temperature range of your experiment.

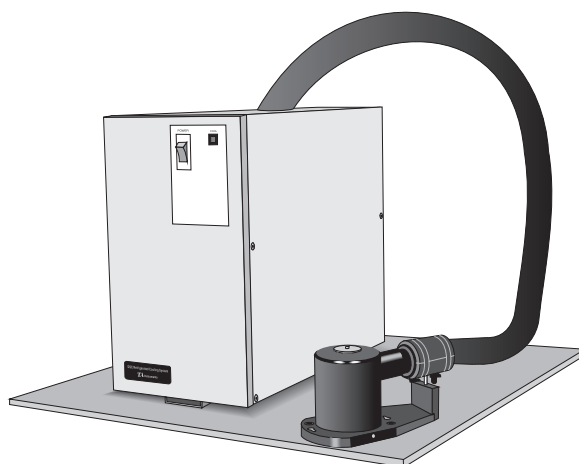

Figure 1.7
Refrigerated Cooling System

DSC Cooling Can

The DSC Cooling Can fits over the standard DSC Cell and has a reservoir into which you can place coolant to cool the cell. Either quench cooling or manual programmed cooling can be performed. The manual programmed cooling requires operator maintenance of the coolant level in the reservoir.

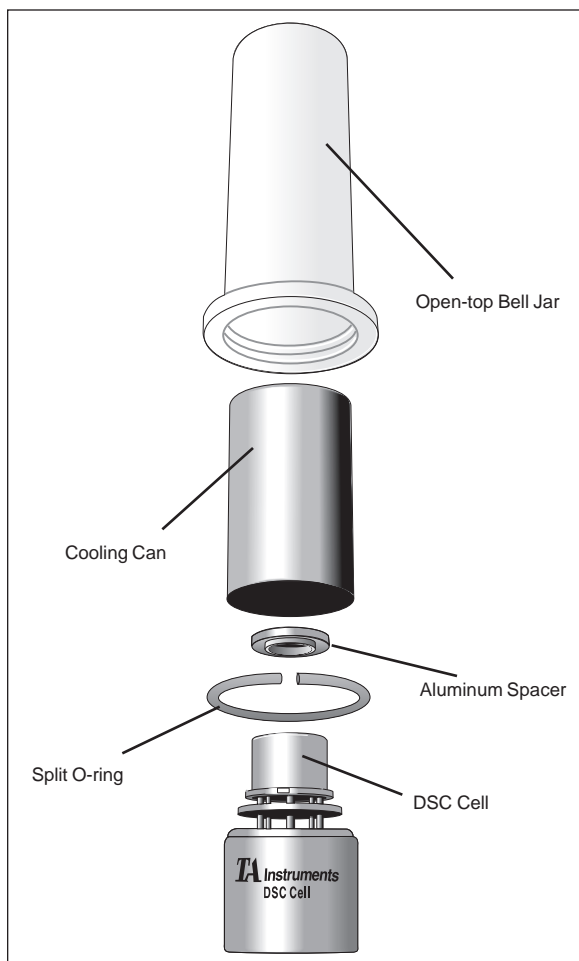

Figure 1.8
DSC Cooling Can

Specifications

Tables 1.2 through 1.3 contain the technical specifications for the 2010 instrument.

Table 1.2
2010 Instrument
Specifications

Dimensions	Depth 65.5 cm (25.8 in.) Width 28.5 cm (11.3in.) Height 40.0 cm (15.7 in.)
Weight (approx.)	20 kg (44 lb)
Power	115 volts AC \pm 10% 50/60 Hz

Table 1.3
2010 DSC Cell
Specifications

Heating Temperature Range	Room temperature to 725°C (inert atmosphere above 600°C) as supplied.
Cooling Temperature Range	-150°C to 725°C with the LNCA and DSC Cooling Can, -70°C to 400°C with the RCS.
Cooling rate	Dependent on accessory used and temperature range
Sample size	0.5 to 100 mg (nominal)
	<i>(table continued)</i>

Table 1.3
(continued)

Sample volume	10 mm ³ in hermetic pans
Sample pans	Various open or hermetically sealed
Atmosphere	Atmospheric to 266 Pa (2 torr); preheated dynamic gas purge (in excess of 100 mL/min)
Purge Gases	Recommended: air, argon, helium, nitrogen, or oxygen
Typical flow rate	25-50 mL/min
Cell volume	2 cm ³
Temperature	±0.1°C repeatability
Differential thermocouples	CHROMEL®*-constantan
Sample thermocouple	CHROMEL®*-ALUMEL®*
Control thermocouple	Platinel II**
Calorimetric sensitivity	1 μW (rms)
	(table continued)

* CHROMEL® and ALUMEL® are registered trademarks of the Hoskins Manufacturing Company.

**Platinel is a registered trademark of Engelhard Industries.

Table 1.3
(continued)

Constant calorimetric sensitivity	$\pm 2.5\%$ from -100 to 500°C
Calorimetric precision	1% (based on metal samples)
Baseline noise	0.5 μW (rms)

CHAPTER 2: Installation

Unpacking/Repacking the 2010	2-3
Unpacking the 2010	2-3
Unpacking the DSC Cell	2-6
Repacking the 2010	2-6
Installing the 2010 Instrument	2-7
Inspecting the System	2-7
Choosing a Location	2-8
Connecting Cables and Gas Lines	2-9
GPIB Cable	2-9
Purge, Vacuum, and Cooling Gas Lines	2-12
PURGE Line	2-12
VACUUM Line	2-13
COOLING GAS Line	2-13
Power Cable	2-15
Installations for Subambient Operation ...	2-16
Installing the DSC Cooling Can	2-17
Starting the 2010	2-20
Shutting Down the 2010	2-21

Installation

Unpacking/Repacking the 2010

NOTE:

These instructions are also found as separate unpacking instructions in the shipping box.

Refer to Figures 1 to 3 while unpacking your instrument.

Unpacking the 2010



Have an assistant help you unpack this unit. Do not attempt to do this alone.

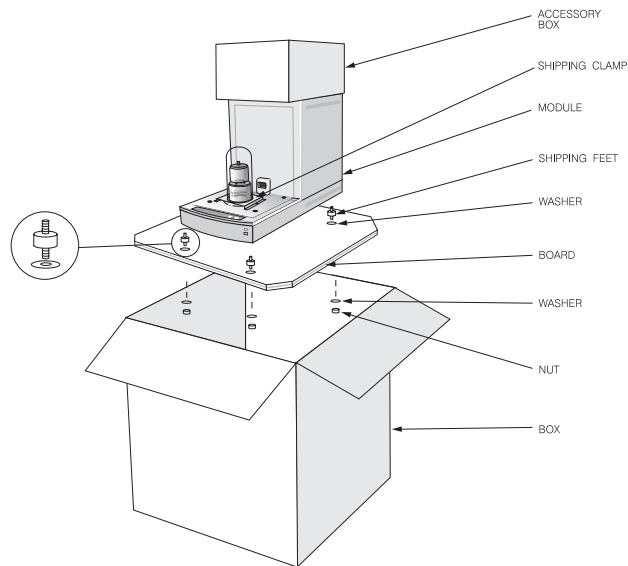

Figure 2.1
Shipping Boxes

1. Open the shipping carton and remove the accessory box.

2. Remove the cardboard packing insert.
3. Stand at one end of the box with your assistant facing you at the other end. Lift your end of the unit out of the box as your assistant lifts his/her end.
4. Place the unit on a lab bench with one side hanging over the edge of the bench (see Figure 2.2). **Someone must be holding onto the unit at all times while it is in this position.**

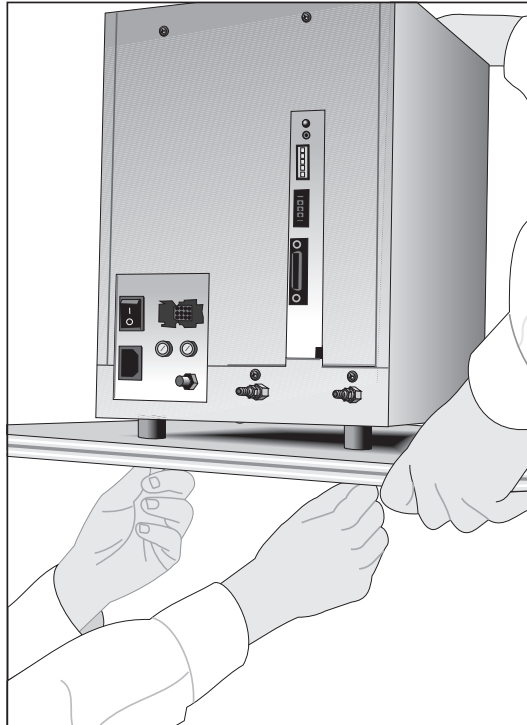

Figure 2.2
Removing the Plywood Board

5. While your assistant holds the unit, use a wrench to remove the two nuts and washers from the bottom. Then lift and rotate the unit so that the other end hangs over the edge of the bench. **Someone must hold onto the unit at all times while it is in this position.** While your assistant holds the unit, remove the two nuts and washers from the other side.
6. Slide the unit completely onto the lab bench. Have your assistant hold one side up while you unscrew and remove the black rubber shipping feet from the bottom. Then rotate the unit and remove the shipping feet from the other side in the same manner.
7. Have your assistant lift one side of the unit while you install two mounting feet on one side (see Figure 2.3). Screw in about 1/4-inch of the threaded mounting post into the unit. Rotate the unit and install the two remaining mounting feet in the same manner.
8. Have your assistant lift the entire unit while you slide the plywood board out from under it.

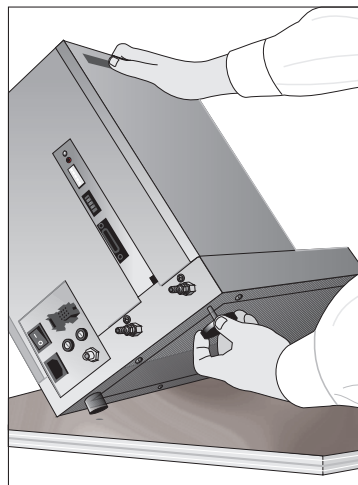

Figure 2.3
Installing the
Mounting Feet

Unpacking the DSC Cell

To unpack the DSC Cell on the 2010 instrument, follow the instructions below.

1. Remove the hold-down screws from the DSC bell jar shipping clamp. Remove the clamp. Install plugs (supplied in the accessory kit) into the holes.
2. Remove the bell jar from the cell. Remove and discard all packing material, such as tape and polyethylene film.
3. Place the silver lid and cell cover (found in the accessory kit) over the cell. The knob on the silver lid should be pointing up. Replace the bell jar over the cell.

Repacking the 2010

To pack and ship your instrument, use the hardware retained during unpacking and reverse the instructions found on pages 2-3 to 2-6.

Installing the Instrument

Before shipment, the 2010 instrument is inspected both electrically and mechanically so that it is ready for operation after it has been installed. Installation involves the following procedures, described in this chapter:

- Unpacking the 2010 instrument and its components and accessory kit
- Inspecting the system for shipping damage and missing parts
- Connecting the instrument to the TA Instruments controller
- Connecting the gas and vacuum lines, accessories, and power cable.

If you wish to have your 2010 instrument installed by a TA Instruments Service Representative, call for an installation appointment when you receive your instrument.

Inspecting the System

When you receive your 2010 instrument, look over the instrument and shipping container carefully for signs of shipping damage, and check the parts received against the enclosed shipping list.

If the instrument is damaged, notify the carrier and TA Instruments immediately.

If the instrument is intact but parts are missing, contact TA Instruments.

A list of TA Instruments offices can be found in Appendix B of this manual.

Choosing a Location

Because of the sensitivity of DSC experiments, it is important to choose a proper location for the instrument. The 2010 instrument should be:

- In
 - ... a temperature-controlled area.
 - ... a clean environment.
 - ... an area with ample working and ventilation space. (Refer to the specifications in Chapter 1 for the instrument's dimensions.)
- On
 - ... a stable work surface.
- Near
 - ... a power outlet (115 volts AC, 50 or 60 Hz, 15 amps). A step up/down line transformer may be required if the unit is operated at a higher or lower line voltage.
 - ... your TA Instruments controller.
 - ... a compressed lab air and purge gas supply for use during cooling and subambient experiments.
- Away from
 - ... dusty environments.
 - ... exposure to direct sunlight.
 - ... direct air drafts (fans, room air ducts).
 - ... poorly ventilated areas.

NOTE:

Drying out the instrument may be needed if it has been exposed to humid conditions. Certain ceramic materials used in this equipment may absorb moisture, causing leakage currents to exceed those specified in the applicable standards until moisture is eliminated. It is important that the instrument ground is adequately connected to the facilities ground for safe operation.

Run this method to dry out the instrument:

- 1 Ramp at 10°C/min to 400°C
- 2 Isothermal for 30 min.

Connecting Cables and Gas Lines

To connect the cables and gas lines, you will need access to the 2010 instrument's rear panel. All directional descriptions are written on the assumption that you are facing the back of the instrument.

Connect all cables before connecting the power cords to outlets. Tighten thumbscrews on all computer cables.

Whenever plugging or unplugging power cords, handle them by the plugs, not by the cords.

Protect power and communications cable paths. Do not create tripping hazards by laying cables across accessways.

GPIB Cable

1. Locate the GPIB connector on the right rear of the 2010 instrument (see Figure 2.4).
2. Connect the GPIB cable to the connector. The GPIB cable is the only cable that fits into the connector.
3. Tighten the hold-down screws on the connector.
4. Connect the other end of the GPIB cable to the controller or to the GPIB cable of another instrument connected to the controller.

5. Select a unique address from 1 to 9 (one that is not used by any other instruments or Instrument Interfaces connected to your controller). Then use the binary address switches on the 2010 instrument connector panel to set the desired address (see Table 2.1). Figure 2.5 shows a instrument address of 7.

If you change the address after the instrument is powered on, you must press the reset button on the instrument to enter the new address.

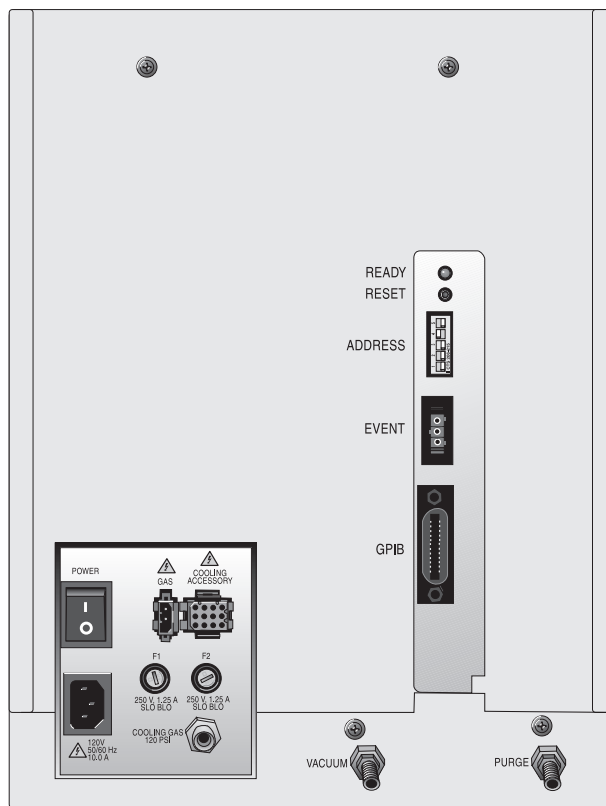

Figure 2.4
2010 Instrument
Connector Panel

Table 2.1
Binary Address Settings*

Address	Switch Pattern
	1 2 3 4 5
1	0 0 0 0 1
2	0 0 0 1 0
3	0 0 0 1 1
4	0 0 1 0 0
5	0 0 1 0 1
6	0 0 1 1 0
7	0 0 1 1 1
8	0 1 0 0 0
9	0 1 0 0 1

*0 = OFF; 1 = ON

Figure 2.5
Binary Address Switches
(Shown as Binary Address #7)

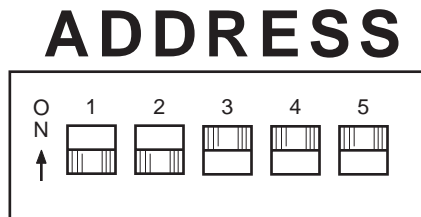

Purge, Vacuum, and Cooling Gas Lines

PURGE Line

The PURGE gas is typically used to control the environment around the sample.

1. Locate the PURGE fitting on the right side of the 2010 instrument back (see Figure 2.6).

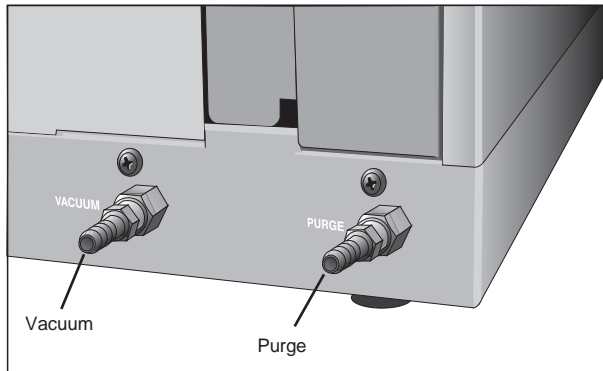

Figure 2.6
PURGE and
VACUUM Fittings

2. Make sure your purge source is regulated between 5 and 30 psi and connected to a flow meter to regulate flow up to 150 mL/min.



Use of any explosive gas as a purge gas is dangerous and is not recommended for the DSC 2010 instrument.

◆ **CAUTION:**

Use of corrosive gases will shorten the life of the instrument and the cell.

3. Connect the DSC 2010 purge fitting to a source of gas using a 1/4-inch I.D. flexible tubing.

VACUUM Line

The vacuum line will be needed if you are going to perform subambient experiments. Connect the line as follows:

1. Locate the VACUUM fitting on the right side of the 2010 instrument back (see Figure 2.6).
2. Connect the DSC 2010 VACUUM fitting to a source of dry nitrogen using 6.4 mm (¼-inch) I.D. flexible tubing.

NOTE:

To minimize moisture build-up during subambient experiments, supply a dry nitrogen purge to the vacuum line using a rate of 100-150 ml/min.

COOLING GAS Line

If you intend to use cooling gas at the end of the experiment, install a split O-ring to prevent vibration of the bell jar. A split O-ring is provided with the DSC Cooling Can. If you do not have a split O-ring, you can order one from TA Instruments (see Appendix B) or cut the one that comes with the DSC Cell.

NOTE:

O-rings are not used if the DSC 2010 is used with an automated cooling system such as the RCS or LNCA.

To connect the COOLING GAS line:

1. Locate the COOLING GAS fitting, a 6.4 mm (¼-inch) compression fitting on the left side of the 2010 instrument back, marked with a 120 psi maximum warning label (see Figure 2.7).

2. Make sure your cooling gas source is regulated between 20 and 120 psi.

NOTE:

The COOLING GAS line ties into a pressure-regulated valve that is set to 15 psi. The source pressure setting should not go below this value.

3. Connect a compressed air line to the COOLING GAS fitting.

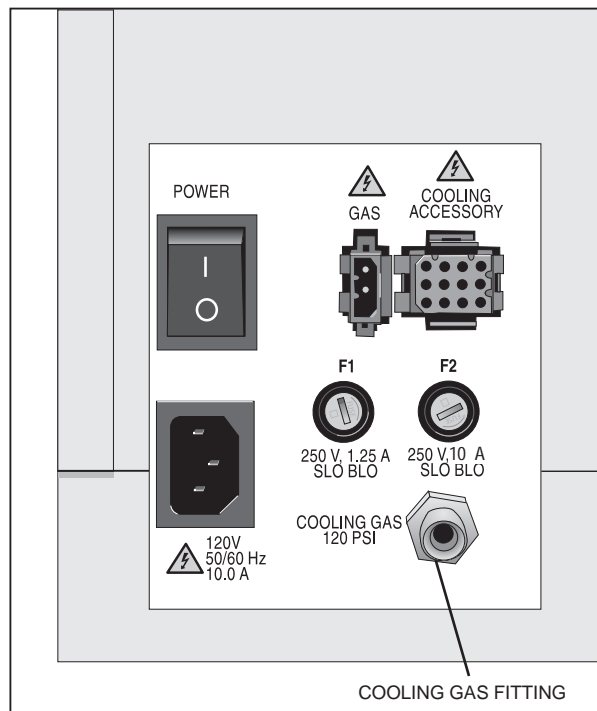

Figure 2.7
COOLING GAS Fitting

Power Cable

NOTE:

Connect all other cables and gas lines before connecting the power cable to a wall outlet.

1. Make sure the 2010 instrument POWER switch (see Figure 2.8) is in the OFF (0) position.

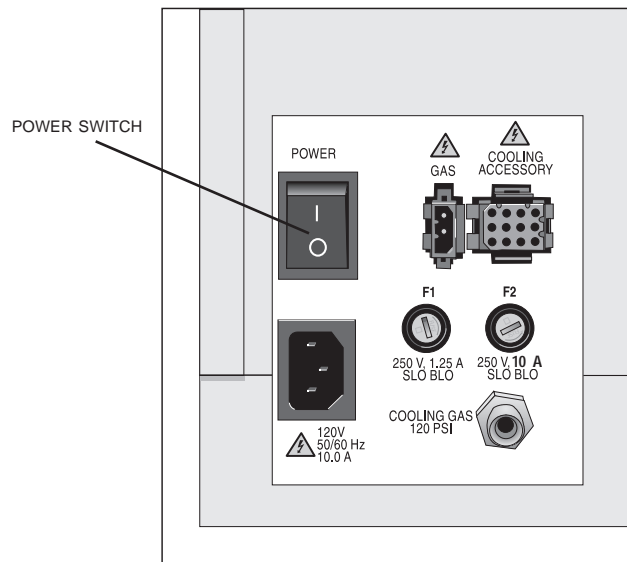

Figure 2.8
2010 Instrument
POWER Switch

2. Plug the power cable into the 2010 instrument.

◆ CAUTION:

Before plugging the 2010 instrument power cable into the wall outlet, make sure the instrument is compatible with the line voltage. Check the label on the back of the unit to verify the voltage.

3. Plug the power cable into the wall outlet.

Installations for Subambient Operation

The standard DSC Cell can be operated at subambient conditions using any one of the following cooling accessories:

- Liquid Nitrogen Cooling Accessory (LNCA) with the DSC Heat Exchanger
- Refrigerated Cooling System (RCS)
- DSC Cooling Can.

This section describes how to install the DSC Cooling Can accessory. The installation of the LNCA and the RCS with the DSC 2010 can be found in the literature accompanying those accessories.

Installing the DSC Cooling Can

The DSC Cooling Can is a metal can that fits over the DSC Cell. Coolant is placed in a reservoir in the top of the can. An open-top bell jar, a Teflon* disc, an aluminum spacer, and a split O-ring are included with the accessory.

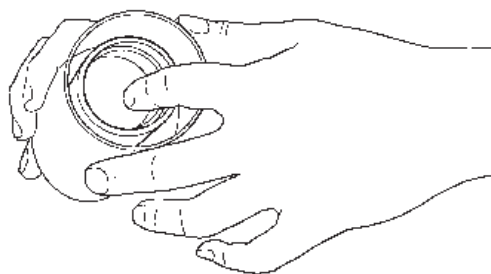

Figure 2.9
Installing the Teflon Disc
in the DSC Cooling Can

The installations for quench and programmed cooling are the same, with one exception: the Teflon disc is used for programmed cooling *only*. The disc is *permanent* once inserted, so the DSC Cooling Can can be used for only one type of cooling once it is installed: quench or programmed. Be sure to determine which type of cooling you plan to use before you install this accessory.

The components installed in the following steps are in the parts bag shipped with the DSC Cooling Can:

1. Remove the bell jar from the DSC Cell. Remove the original O-ring and replace it with the split O-ring shipped with the DSC Cooling Can.

* Teflon is a registered trademark of the DuPont Company.

2. If you plan to do *programmed* cooling experiments with the DSC Cooling Can, first punch a 2-cm hole in the center of the insulation disc. This allows you to remove the disc from the can later by prying up the edge of the hole with a tool. Place the insulation disc inside the can by turning the cooling can upside down, putting the disc into the can, and pushing the disc until it snaps into place (see Figure 2.9).

NOTE:

Once the Teflon disc is installed, you cannot remove it; the DSC Cooling Can will be set up permanently for programmed cooling.

◆ CAUTION:

The insulation disc will soften at 325°C.

If you plan to do *quench* cooling experiments with the DSC Cooling Can, *do not* install the Teflon disc.

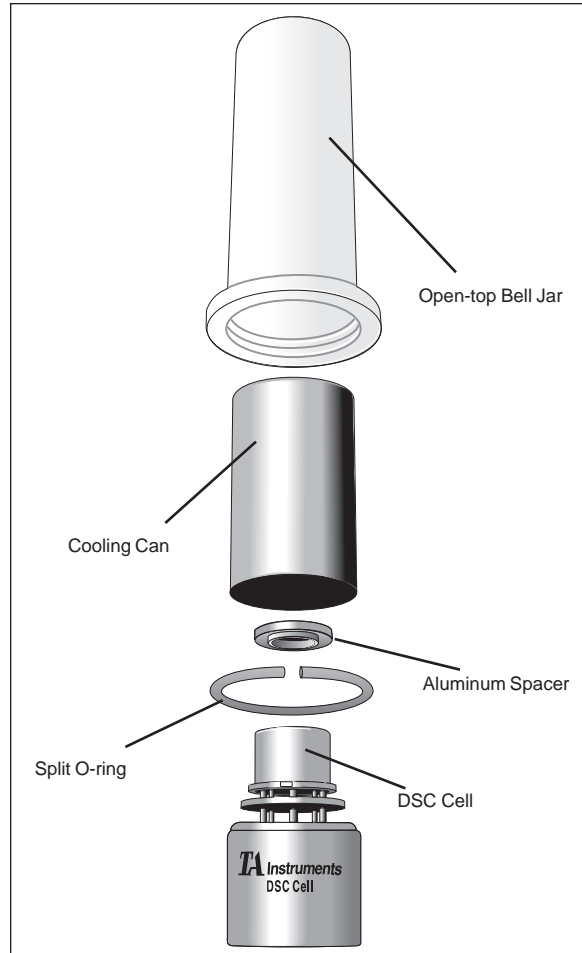

Figure 2.10
Installing the DSC
Cooling Can

3. Place the aluminum spacer on top of the cell as shown in Figure 2.10.
4. Place the DSC Cooling Can over the DSC Cell.
5. Place the open-top bell jar over the DSC CoolingCan.

NOTE:

When running subambient experiments, use a dry nitrogen purge through the vacuum port (~100 – 150 ml/min) and a dry gas through the purge port to eliminate moisture buildup.

Starting the DSC 2010

NOTE:

|| Allow the 2010 instrument to warm up for at least 30 minutes before performing an experiment.

1. Check all connections between the 2010 instrument and the controller. Make sure each component is plugged into the correct connector.
2. Press the instrument POWER switch, located on the rear of the instrument, to the ON position. The green power light on the front of the instrument should turn on and the yellow Ready light should flash.
3. Make sure the green power light comes on; if it does not, recheck the power connections to the instrument and the power source. If the connections are good, check the instrument power fuse F1 on the rear of the instrument to see if the fuse is blown. If the fuse is blown, replace it, see Chapter 5.

You are now ready to start up the rest of the thermal analysis system.

Shutting Down the 2010 Instrument

Before you decide to power down your 2010 instrument, consider the following:

- All of the components of your thermal analysis system are designed to be left on for long periods.
- The electronics of the 2010 instrument and the controller perform more reliably if power fluctuations caused by turning units on and off are minimized.

For these reasons, turning the system and its components on and off frequently is discouraged.

When you finish running an experiment on your 2010 instrument and wish to use the thermal analysis system for some other task, leave the instrument on; it will not interfere with whatever else you wish to do.

If you do need to power down your 2010 instrument for any reason, simply press the POWER switch to the OFF position.

Installation

CHAPTER 3: Running Experiments

Overview	3-3
Before You Begin	3-3
Calibrating the DSC	3-4
Baseline Slope and Offset Calibration	3-5
Cell Constant Calibration	3-6
Temperature Calibration	3-6
Running a DSC Experiment	3-7
Experimental Procedure	3-7
Preparing Samples	3-8
Determining Sample Size	3-8
Physical Characteristics	3-9
Selecting Sample Pans	3-9
Sample Pan Material	3-9
Sample Pan Configuration	3-11
Nonhermetic Pans	3-11
Hermetic Pans	3-11
Open Pans	3-12
SFI Pans	3-12
Encapsulating the Sample	3-12
Preparing Nonhermetic Sample Pans	3-13
Preparing Hermetic Sample Pans	3-16
Setting Up Accessories	3-19
Loading the Sample	3-21

Running Experiments

Starting an Experiment	3-23
Stopping an Experiment	3-23
Subambient Experiments	3-24
DSC Cooling Can	3-24
Applications	3-24
Operation	3-25
Quench-Cooling Between Runs	3-25
Starting a Run Below Ambient Temperature	3-26
Programmed Cooling	3-26

Overview

This chapter gives step-by-step instructions on how to run experiments with the 2010 instrument.

To obtain accurate results, follow the procedures carefully, and check the calibration periodically (*e.g.*, once a week).

Only the instructions necessary for running experiments are given in this chapter; explanations of terminology and how the instrument operates are given in Chapter 4, “Technical Reference.”

Before You Begin

Before you set up an experiment, ensure that the 2010 instrument, and the TA controller have been installed properly. Make sure you have:

- Made all necessary cable connections from the 2010 instrument to the TA controller
- Connected all gas lines
- Powered up each unit (see Chapter 2)
- Installed all appropriate options
- Loaded the TA Operating System on the controller
- Become familiar with controller operations
- Calibrated the instrument, if necessary.

Calibrating the DSC

To obtain accurate experimental results you should calibrate the cell when you first install the instrument. Once the initial calibrations are done, you can save the resulting data files and reuse them when needed. For the best results, however, you should recalibrate periodically.

Perform calibration runs that encompass the temperature range you plan to use in your experiments. If you change the general temperature range of your experiments later, you may wish to recalibrate within the new range.

For precise experimental results you will need to generate a new calibration file whenever you change one of the following parameters:

- Ramp rate (selected in the thermal method)
- Purge gas
- Cooling technique (LNCA, RCS, or DSC Cooling Can).

However, an acceptable alternative is to use a previous calibration, if the conditions are sufficiently similar to those of the experiments you plan to run. Calibration is performed in the instrument's calibration mode, which is accessed through the controller.

For more details on performing each type of calibration refer to the instructions in the Thermal Solutions *User Reference Guide*.

Baseline Slope and Offset Calibration

This calibration involves heating an empty cell through the entire temperature range expected in subsequent experiments. The results may look similar to Figure 3.1. This figure shows two example heat flow curves for an empty standard DSC cell run from 25 to 400°C. Ideally, the heat flow signal should be zero, since there is no sample in the cell and it should have minimum slope. The calibration program is used to calculate the slope and offset values needed to flatten the baseline and zero the heat flow signal.

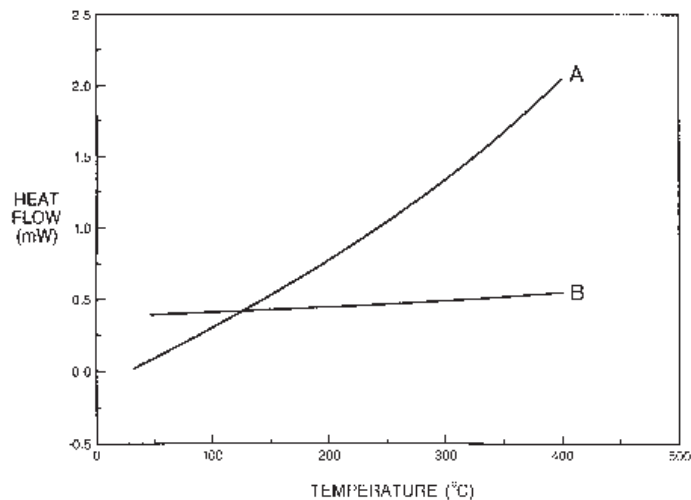

Figure 3.1
Baseline Slope
Calibration

Cell Constant Calibration

This calibration is based on a run in which a calibration material (*e.g.*, indium) is heated through its melting point. The calculated heat of fusion is compared to the theoretical value. The cell constant is the ratio between these two values. The onset slope, or thermal resistance, is a measure of the temperature drop that occurs in a melting sample in relation to the thermocouple. Theoretically, a calibration material should melt at a constant temperature. As it melts and draws more heat, a temperature difference develops between the sample and the sample thermocouple. The thermal resistance between these two points is calculated as the onset slope of the heat flow versus temperature curve on the front of the melting peak. The onset value is used for kinetic and purity calculations to correct for this thermal resistance.

Temperature Calibration

Temperature calibration is based on a run in which a calibration material (*e.g.*, indium) is heated through its melting point. The recorded melting point of this material is compared to the known melting point, and the difference is calculated for temperature calibration. The same file used for the cell constant calibration can be used for this calibration.

In addition, you can use up to four other standards to calibrate temperature. If you use one pair of known and observed points, the entire curve is offset, or shifted, to the actual melting point. If you use multiple standards, the temperature is corrected by a cubic spline fit. The multiple-point temperature calibration is more accurate than the one-point calibration.

Running a DSC Experiment

Experimental Procedure

Your DSC experiments will have the following general outline:

- *Selecting and preparing a sample.* This involves preparing a sample of the appropriate size and weight, selecting the pan type and material, and encapsulating the sample in the pan.
- *Loading the sample pan* (and a similarly prepared empty reference pan) into the cell
- *Entering experiment information* through the TA controller (sample and instrument information)
- *Creating and selecting the thermal method* on the controller
- *Attaching and setting up external accessories* as required (e.g., purge gas, LNCA)
- *Starting the experiment.*

Preparing Samples

Determining Sample Size

Normally, sample weight in DSC experiments is in the range of 5 to 20 milligrams. If purity determinations are to be performed, then sample sizes of 1 to 3 milligrams are recommended. Refer to Table 3.1 as a general guide for selecting sample size and heating rates for your experiment.

Table 3.1
Determining
Sample Size

Type of Measurement	Sample Size (mg)	Heating Rate (°C/min)
glass transition (T_g)	10 to 20	10 to 20
melting point (T_m)	2 to 10	5 to 10
kinetics (Borchardt & Daniels)	5 to 10	5 to 20
kinetics (ASTM)	*	0.5 to 20
heat capacity (C_p)	10 to 70	20
purity	1 to 3	0.5 to 1
crystallinity or oxidative stability	5 to 10	5 to 10

*Mass is inversely proportional to the heating rate. Use larger masses at slower rates, smaller masses at higher rates.

Physical Characteristics

When making quantitative measurements or verifying reproducibility, it is important to ensure good thermal contact between the sample and sample pan. The physical characteristics of the sample affect the quality of this contact.

When using powdered or granular samples, spread them evenly across the bottom of the pan to minimize thermal gradients. For solid samples, select the side of your sample with the flattest surface for contact with the pan. After encapsulating the sample, ensure that the pan bottom is flat. If it is not, flatten it by pressing the pan bottom on a flat surface.

NOTE:

The contact between the sample and sample pan is as important as the contact between the pan and the raised sample platform on the constantan disc.

Selecting Sample Pans

DSC samples must be in sample pans for analysis. Use the following guidelines to select a sample pan material and configuration that meets the temperature and pressure range, composition, and reactivity requirements of your experiment.

Sample Pan Material

Aluminum pans can be used in most experiments, unless the sample material reacts with aluminum or the temperature is expected to go beyond that allowable for aluminum pans. Many other sample pan materials are available for experiments with special requirements. For example, you may wish to choose a particular pan material to improve the thermal conductance to the sample.

Sample pans made of platinum, copper, or gold are commonly used when the sample reacts with aluminum or has a transition in the 600 to 725°C region; sample pans made of graphite are used when alloying or other undesirable metal-sample interactions occur. The many pan materials available enable you to study a wide variety of sample materials over the temperature range of the DSC cell.

Table 3.2 provides guidelines for one of the most important factors in the selection of a sample pan metal: the temperature range you plan to use in the experiment.

Table 3.2
TA Instruments
DSC Sample Pan
Temperature Ranges

Sample Pan	Usable Temperature Range (°C)
aluminum	-180 to 600
copper	-180 to 725
gold	-180 to 725
platinum	-180 to 725
graphite	-180 to 725
aluminum (SFI)*	-180 to 600
aluminum [hermetic to 300 kPa (3 atm) internal pressure]	-180 to 600
alodined aluminum [hermetic to 300 kPa (3 atm) internal pressure]	-180 to 200
gold [hermetic to 600 kPa (6 atm) internal pressure]	-180 to 725
*SFI = solid fat index	

Sample Pan Configuration

Once you have selected the sample pan material to be used, you must determine the appropriate sample pan configuration. Depending on the requirements of the experiment, samples can be contained in:

- Nonhermetic pans
- Hermetic pans
- Open pans (sample pans without lids).

Nonhermetic Pans

Most samples can be run in nonhermetically crimped aluminum sample pans. These pans provide better thermal contact between sample, pan, and constantan disc than open pans; reduce thermal gradients in the sample; minimize sample spills; and enable you to retain the sample for further study.

Hermetic Pans

Hermetically sealed sample pans have the same advantages as the nonhermetic pans, plus they have an airtight seal that can resist higher internal pressures (see Table 3.2). These pans are used for studies of: volatile liquids, materials that sublime, aqueous solutions above 100°C, and materials in a self-generated atmosphere. Because of its larger mass, a hermetic pan causes a slight loss of resolution compared with a nonhermetic pan; however, only the system time constant is affected, not the calorimetric accuracy.

Open Pans

Open pans (sample pans without lids) are used when contact with the cell atmosphere or reaction of the sample with a gas is required. You can also use hermetic pans as open pans by putting a pinhole in the lid before sealing.

SFI Pans

SFI pans (so named because they were first developed for the solid fat index test) are ideal for waxy or oily substances. They contain a platform on which the substance sits, which prevents the substance from “wicking” up the sides of the pan. This maintains a constant surface area during the experiment, which is especially important in oxidative studies, in which increased surface area could result in faster oxidation.

Encapsulating the Sample

The Sample Encapsulating Press is used to seal both nonhermetic and hermetic sample pans. Refer to Table 3.3 as a general guide for selecting the encapsulating method for your experiment.

Table 3.3
Selecting an
Encapsulating Method

Sample Type	Measurement	Pan Type
solid (nonvolatile)	T_g or T_m oxidative stability C_p	nonhermetic, hermetic, SFI or open nonhermetic
solid (volatile)	C_p	hermetic
liquid	crystal- lization T_g or T_m C_p oxidative	hermetic, SFI, or open hermetic SFI or open
aqueous solution	C_p , T_m , T_g	alodined aluminum hermetic

Preparing Nonhermetic Sample Pans

Before using the Sample Encapsulating Press, ensure that it is set up for nonhermetic crimping (see Appendix A).

Practice making a few nonhermetic sample pans to become familiar with this procedure before encapsulating your samples. If you have just changed the die (from hermetic to nonhermetic), make a few sample pans to ensure that the die has been installed properly.

1. If you will be doing quantitative work, weigh the sample pan and lid.

NOTE:

When doing quantitative work, use tweezers to handle the sample pan and lid. Touching them with your fingers could leave residue that could affect your results.

2. Place the sample in the pan. If you are using a powder or granular sample, spread it evenly in the pan.
3. Place a lid on the pan.
 - If the sample is small or thin, powder, or granular, align the lid with the pan (see Figure 3.2).
 - If the sample is large or bulky, invert the lid and place it in the pan.

NOTE:

Pans used with inverted lids should not be crimped.

Figure 3.2
Placing the
Cover Over the Pan

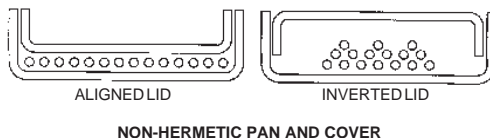

4. Place the sample pan in the well of the lower crimping die.
5. Pull the Sample Press lever forward until the handle hits the stop.
6. Raise the lever and remove the pan with tweezers.

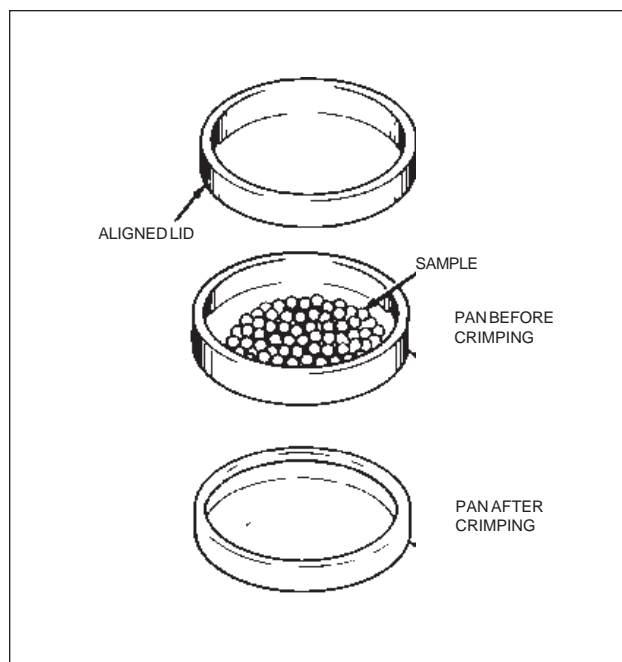

Figure 3.3
Nonhermetically
Crimped Pans

7. Inspect the pan. The bottom of the pan should be smooth, and the sides should appear rolled down. If there is a ridge on the bottom of the pan, loosen the lower die holder thumbscrew and lower the bottom die holder about $\frac{1}{4}$ -turn by turning it clockwise, and repeat the process from step 4.

Adjust the bottom die holder until you obtain a flat pan bottom. Then, lock the bottom die holder in place by tightening the lower die holder thumbscrew.

NOTE:

Large or bulky samples may rupture the pan lid. If the lid ruptures, lower the bottom die holder. Slight deformation of the lid is acceptable.

8. For quantitative work, weigh the crimped sample pan and lid (containing the sample) and determine the sample weight by subtracting the weight of the empty sample pan and lid (step 1).
9. Prepare an empty nonhermetic pan and lid (follow steps 3 through 7) for use as the reference pan.

NOTE:

It is important that the same care be taken in preparing the reference pan as in preparing the sample pan. The pan bottom should be flat.

Preparing Hermetic Sample Pans

Before using the Sample Encapsulating Press, ensure that it is set up for hermetic crimping (see Appendix A).

Practice making a few hermetic sample pans to become familiar with this procedure before encapsulating your samples. If you have just changed the die (from nonhermetic to hermetic), make a few hermetic sample pans to ensure that the die has been installed properly.

To prepare a hermetic sample pan:

1. For quantitative work, weigh the sample pan and lid.

NOTE:

When doing quantitative work, use tweezers to handle the sample pan and lid. Touching them with your fingers could leave residue that could affect your results.

2. Carefully place the sample in the pan. Do not allow the sample to spill onto the lip of the pan. Put the hermetic lid on the pan, and place the pan in the lower die in the Sample Press.

NOTE:

When using solid samples in hermetic pans for quantitative calorimetric measurements, invert the cover to improve sample-to-pan contact and minimize dead volume. This is especially important for purity analyses.

3. Place the flat side of the preforming tool against the upper die and hold it in place. With your other hand, pull the Sample Press lever forward until the preforming tool hits the stop.
4. Raise the lever and remove the preforming tool.
5. Lower the lever again with a steady motion until the handle hits the stop. Raise the lever and remove the pan with tweezers.
6. Inspect the pan. The bottom of the pan should be smooth, and there should be a smooth, complete seal around the circumference (as opposed to the rolled down appearance of a nonhermetic pan), indicating a tight seal.

7. For quantitative work, weigh the pan to determine the sample weight.
8. Prepare an empty hermetic pan and lid for use as the reference pan.

NOTE:

It is important that the same care be taken in preparing the reference pan as in preparing the sample pan. The pan bottom should be flat.

Setting Up Accessories

If your experiment requires additional accessories, such as a purge gas or the LNCA, ensure that they are turned on, and make any necessary adjustments before you start your experiment. Ensure that the system can achieve the temperatures in all segments of the method (*e.g.*, if subambient temperatures are required, make sure your cooling device is properly installed and filled). Use the following table as a guide in checking your DSC accessories.

Table 3.4
DSC Accessory
Adjustments

External Equipment	Check /Adjust:
Air cool	<p>Ensure that the air supply line valve from the air source is open.</p> <p>Ensure that the pressure is between 20 and 120 psi.</p>
Purge gas	<p>Make sure the correct gas is connected to the 2010 instrument.</p> <p>Ensure that your supply of purge gas is sufficient for the needs of the experiment.</p> <p>Set the purge gas flow rate.</p> <p><i>(table continued)</i></p>

Table 3.4
(continued)

External Equipment	Check /Adjust:
LNCA	<p>Fill the LNCA tank with liquid nitrogen (see your LNCA Operator's Manual).</p> <p>Make sure the LNCA is connected to the 2010 instrument.</p> <p>Turn on the LNCA.</p> <p>NOTE: Operation of the LNCA with the 2010 instrument is completely automatic as long as the power to the LNCA is on. The 2010 will override the LNCA controls, so there is no need to adjust them.</p>
Refrigerated Cooling System	<p>Install the RCS Cooling Head over the cell and turn on the RCS.</p> <p>Turn on the RCS and leave it on for 15 to 20 minutes. Ensure that second-stage cooling has activated before you begin the run.</p> <p><i>(table continued)</i></p>

Table 3.4 (continued)

External Equipment	Check/Adjust:
DSC Cooling Can	Install the DSC Cooling Can over the cell and fill with the desired coolant. Be ready to add more coolant as needed during the experiment.
Gas Switching Accessory	Make sure the power switch is on. Make sure the necessary gas source(s) are properly connected.

Loading the Sample

Once the sample pan has been prepared and pre-experiment data has been recorded, you are ready to load the sample pan into the DSC Cell.



If the cell has just been used, the components of the cell could be very hot. As a safe operating practice, use the tweezers whenever handling the cell cover or silver lid.

Load the sample pan into the cell as follows:

1. Remove the bell jar, cell cover, and silver lid from the cell.

2. Carefully place the sample pan on the front raised platform and the reference pan on the rear platform. Centering the pans within the grid will ensure that they are centered on the platforms (see Figure 3.4).
3. Replace the silver lid, cell cover, and bell jar.

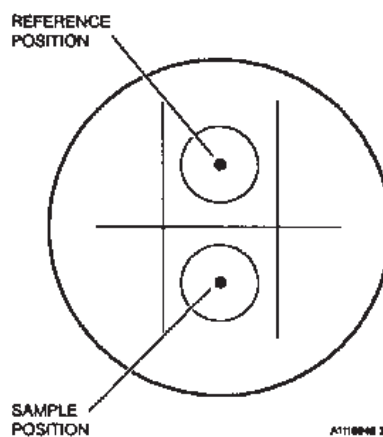

Figure 3.4
DSC Cell
Pan Positions

Starting an Experiment

Before you start the experiment, ensure that the 2010 instrument is online with the controller and you have entered all necessary experimental parameters.

Start the experiment by pressing the START key on the instrument keypad or **Start** from the *Thermal Solutions* DSC Instrument Control program, the instrument will run your method to completion.

Stopping an Experiment

If for some reason you need to discontinue the experiment, you can stop it at any point by pressing either the STOP key on the 2010 instrument keypad or choosing **Stop** on the controller. Another function that stops the experiment is **Reject** on the controller. However, the **Reject** function discards all of the data from the experiment; the **Stop** function saves any data collected up to the point at which the experiment was stopped.

◆ **CAUTION:**

|| The REJECT function discards all experiment data.

Subambient Experiments

Subambient experiments can be performed with the DSC 2010 using the Liquid Nitrogen Cooling Accessory (LNCA), the Refrigerated Cooling System (RCS), and the DSC Cooling Can. Please consult the manuals that come with the LNCA and RCS for operation instructions. Instructions for operating the DSC Cooling Can are given below.

DSC Cooling Can

The DSC Cooling Can fits over the DSC Cell and has a reservoir into which you can place coolant to cool the cell. An open-top bell jar, a Teflon* disc, and a split O-ring are also included with the accessory.

Installation instructions for the DSC Cooling Can are given in Chapter 2.

Applications

The DSC Cooling Can is used:

- To quench-cool (rapid-cool) between analyses. The DSC Cell can be quench-cooled from 700°C to ambient in three minutes.
- To cool to a subambient temperature before a thermal program is started.
- To program-cool (by maintaining coolant level in the reservoir).

* Teflon is a registered trademark of the DuPont Company.

Without the Teflon disc installed, the DSC Cooling Can can be used over the entire temperature range of the DSC cell.

Operation

NOTE:

When the Teflon disc is installed, the DSC Cooling Can should not be placed on a hot cell without coolant in the reservoir. Teflon softens at 325°C.

Quench-Cooling Between Runs

1. Carefully remove the DSC cell cover (it may be hot). Place the DSC Cooling Can (without the Teflon disc) over the DSC Cell and pour in the coolant, typically liquid nitrogen, using the open-top bell jar to minimize frost build-up on the can and DSC cell.



Follow the safety procedures in the front of this manual when handling liquid nitrogen.

2. When the cell cools to ambient, remove the bell jar and the DSC Cooling Can, and place the sample and reference in the cell.
3. Replace the DSC Cooling Can if further cooling is required.

NOTE:

To prevent frost from forming on the constantan disc, do not remove the silver lid when the cell temperature is below ambient.

Starting a Run Below Ambient Temperature

1. Place the sample and reference in the cell at ambient temperature. Install the silver lid but not the cell cover.
2. Place the DSC Cooling Can over the cell, and pour in the coolant using the open-top bell jar to minimize frost.
3. When the starting temperature is reached, remove the DSC Cooling Can, and place the cell cover and bell jar over the cell. Do not remove the silver lid.

Programmed Cooling

◆ **CAUTION:**

Once the Teflon disc is installed, you cannot remove it; the DSC Cooling Can will be set up permanently for programmed cooling.

1. Place the sample and reference in the cell, and install the silver lid.
2. Place the Teflon disc in the DSC Cooling Can to minimize baseline disturbance when the can is refilled.

NOTE:

Teflon softens at 325°C. When the Teflon disc is installed, the DSC Cooling Can should not be placed on a hot cell without coolant in the reservoir.

3. Place the DSC Cooling Can and open-top bell jar over the cell, and pour in the coolant.
4. Start the programmed cooling. Add coolant as needed to keep the can at least half full during programmed cooling.

CHAPTER 4: Technical Reference

Description of the DSC 2010	4-3
DSC Cell	4-3
Principles of Operation	4-5
Cell Block Heating	4-5
Sample and Reference Thermocouples ...	4-6
DSC Applications	4-7
Sample Types	4-7
Status Codes	4-8
Guidelines for Quantitative Studies	4-12
Specific Heat Experiments	4-12

Description of the DSC 2010

A complete DSC 2010 system includes the 2010 instrument and a controller. Both the temperatures and the heat flow associated with transitions in materials can be easily and rapidly measured by the system. The measurements provide quantitative and qualitative data relative to physical or chemical changes of a material involving endothermic (heat absorption) or exothermic (heat evolution) processes.

DSC Cell

The DSC cell (Figure 4.1) uses a constantan (thermoelectric) disc as a primary heat-transfer element. A silver heating block, capped with a vented silver lid, encloses the constantan disc. The selected sample and an inert reference are placed in pans that sit on raised portions of the disc. Heat is transferred through the constantan disc to both the sample and the reference pan. Differential heat flow to the sample and reference are monitored by the CHROMEL®*-constantan area thermocouples formed at the junctions of the constantan disc and the CHROMEL wafers welded to the underside of the two raised portions of the disc. CHROMEL and ALUMEL®* wires are connected to the CHROMEL wafers at the thermocouple junctions to measure sample temperature. The ALUMEL wire welded to the reference wafer is for thermal balance.

* CHROMEL® and ALUMEL® are registered trademarks of the Hoskins Manufacturing Company.

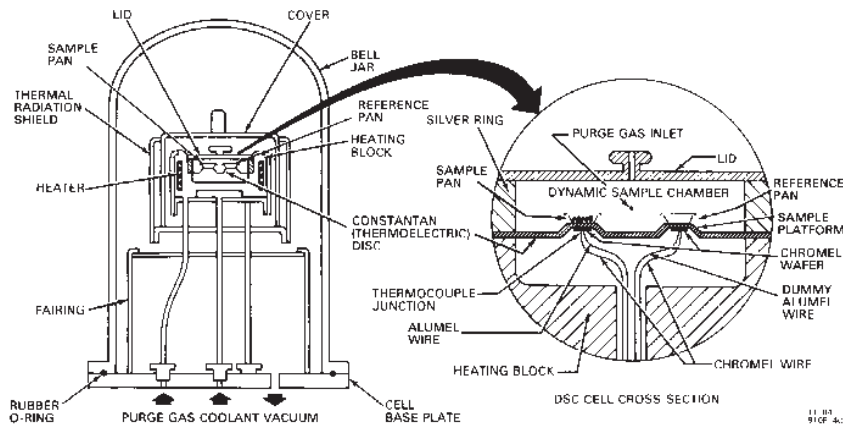

Figure 4.1
DSC Cell Cross-Section

Purge gas is preheated to heating block temperature by circulation within the block before entering the sample chamber through the purge gas inlet. Gas exits through the vent hole in the silver lid.

Vacuum and air cooling ports on the 2010 instrument lead to openings in the cell but not directly to the sample chamber. A bell jar, placed over the cell and sealed with an O-ring, protects the operator from evolved gases and permits cell evacuation.

Principles of Operation

If a sample and an inert reference are heated at a known rate in a controlled environment, the increase in sample and reference temperature will be about the same (depending on specific heat differences), unless a heat-related change takes place in the sample. If this change takes place, the sample temperature either evolves or absorbs heat). In DSC, the temperature difference between sample and reference from such a heat change is directly related to the differential heat flow.

Cell Block Heating

The 2010 instrument controls the cell temperature by heating a silver block with a resistive wound heater and monitoring its temperature with a closely coupled control thermocouple. The appropriate amount of power supplied to the heater is determined by the difference between the temperature measured by the control thermocouple and the set point temperature (the temperature the system is attempting to reach).

Heat from the block then flows radially through the constantan disc toward the sample and reference platforms. The primary means of heat transfer to the sample and reference is through the disc, although some heat is transferred from the lid and walls of the cell through the atmosphere.

The DSC cell uses Platinel II* control thermocouples.

*Platinel II is a registered trademark of Englehard Industries.

Sample and Reference Thermocouples

The sample and reference thermocouples are connected in series opposition (back-to-back) so that if the sample (T_s) and reference (T_r) temperatures are the same, the resulting electrical potential is zero. If the sample temperature is higher than the reference, the output electrical potential is one polarity; if the sample temperature is lower, the polarity is reversed.

The DSC 2010 measures the differential voltage between the thermocouples at the sample and reference platforms. This voltage is linearized/converted to mW.

The sample platform (the front platform) also has an ALUMEL®* lead wire forming a CHROMEL®*-ALUMEL thermocouple junction. The output from this thermocouple is monitored on the T-axis after suitable cold junction compensation. Thus, the signal is determined by CHROMEL-constantan thermocouples, and the sample temperature is measured with a CHROMEL-ALUMEL thermocouple. The DSC cell baseline is very reproducible, and the cell output can be compensated to obtain a level baseline over the cell temperature range with the *Thermal Solutions* calibration functions.

* CHROMEL® and ALUMEL® are registered trademarks of the Hoskins Manufacturing Company.

DSC Applications

Applications of DSC fall into a broad category of materials characterization, including thermal transitions in polymers:

- Glass transitions, crystallization, and melting transitions
- Curing reactions and kinetics of thermosets
- Oxidative stability of lubricants and polymers
- Purity of pharmaceuticals and organics
- Specific heat capacity of materials
- Catalyst efficiency.

Sample Types

The 2010 instrument can be used to analyze virtually any material that can be put into a DSC sample pan. The most important consideration is that the sample must make good thermal contact with the pan. Samples of solids and liquids in any of the following forms can be analyzed:

- Films
- Fibers
- Powders
- Solutions
- Composites.

Status Codes

Status codes are displayed at the top of the *Thermal Solutions* Instrument Control window.

Table 4.1
Method Status Codes

Code	Meaning
Air Cool	The cell is being air cooled by an Air Cool segment or the Air Cool Instrument Control function.
Autofill	The LNCA is being refilled from a low-pressure bulk storage tank.
Calib	The 2010 instrument is running in calibration mode.
Cold	The instrument heater cannot supply heat fast enough to keep up with the thermal program. This may be caused by a large ballistic jump in the program, a faulty heater, or a faulty control thermocouple signal.

(table continued)

Table 4.1
(continued)

Code	Meaning
Complete	The thermal method has finished.
Cooling	The heater is cooling, as specified by a Ramp segment.
Equilib	The temperature is being equilibrated to the desired set point.
Heating	The heater temperature is increasing, as specified by a Ramp segment.
Holding	Thermal experiment conditions are holding; the program is suspended. Choose Start to continue the run.
Hot	The temperature is beyond the set point, and the instrument cannot remove heat fast enough to follow the thermal program. This is usually caused by a large ballistic jump to a lower temperature or by a cooling ramp being run without the LNCA.

(table continued)

Table 4.1
(continued)

Code	Meaning
Initial	The temperature is being equilibrated to the desired set point. When the temperature has reached equilibrium, the status will change to Ready.
Iso	The thermal program is holding the current temperature isothermally.
Iso-track	The instrument is holding the sample at a constant temperature as specified by the Iso-track segment.
Jumping	The heater is jumping ballistically to the set point temperature.
No Power	No power is being measured at the heater. Check the heater fuse.
Ready	The system has equilibrated at the initial temperature and is ready to begin the next segment. Choose Start to continue the method.
Reject	The experiment has been terminated and the data erased.

(table continued)

Table 4.1
(continued)

Code	Meaning
Repeat	The method is executing a repeat loop that does not involve temperature control segments.
Stand by	The method and method-end operations are complete.
Temp	The heater is in stand-by mode, and the experiment has been terminated.

Guidelines for Quantitative Studies

You can obtain ΔH and specific heat data from DSC experiments by following the procedures in this section. Optional heat capacity software greatly simplifies these calculations.

Specific Heat Experiments

If you wish to calculate specific heat, follow the guidelines below when running the sample.

1. Create a baseline profile:
 - a. Load the cell with empty sample and reference pans. Include lids if your experiment will use sealed pans, but do not crimp the sample pan (you will need to reuse it).
 - b. Create a method that holds isothermally at the desired starting temperature for 5 minutes, heats at the desired heat rate, and then holds at the limit temperature for 2 minutes.
 - c. Start the run. Deflection from the initial equilibrium point may be upward or downward, depending on the specific heat difference between the sample and reference pans.

2. Repeat the run under identical conditions with a weighed sample in the same sample pan used for the baseline profile. Do not adjust the baseline slope or use the **Auto Zero A** or **Manual Zero A** option between the runs.
3. Plot the above thermograms with the data analysis program. Use the same limits and intervals in both plots.
4. Calculate the specific heat by measuring the difference in y-axis displacement (calorimetric differential) between the sample and blank curves at any desired temperature (see Figure 4.2).

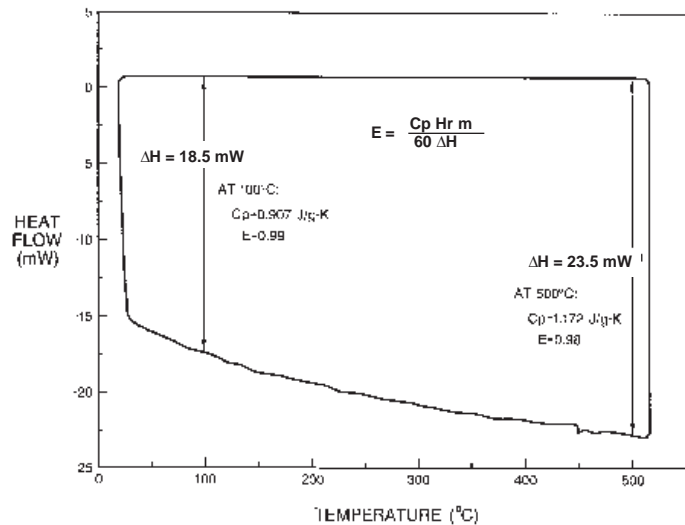

Figure 4.2
Specific Heat
of Sapphire

5. Substitute the difference into the following equation:

$$C_p = \left[\frac{60E}{\text{Hr}} \right] \frac{\Delta H}{\text{m}}$$

where E = cell calibration coefficient at the temperature of interest (dimensionless)

Hr = heating rate, in °C/minute

ΔH = difference in y -axis deflection between sample and blank curves at the temperature of interest, in mW

m = sample mass, in mg

C_p = specific heat, in J/g°C

The quantity $60E/Hr$ is constant under a given set of experimental conditions. It converts the y measurement directly into units of specific heat in J/g°C. For greatest accuracy, determine the value of this constant (as an entity) by running a standard material of known specific heat under conditions identical to those of the unknown sample. Then substitute the values of H , m , and C_p for the standard into the above equation at the temperature of interest.

A sapphire (Al_2O_3) standard is provided in the accessory kit for this purpose. Table 4.4 (pages 4-15 to 4-18) shows its respective specific heat values.

The values in the table were determined by Ginnings and Furukawa of the National Bureau of Standards on aluminum oxide in the form of synthetic sapphire (corundum). The sapphire pieces passed a #10 sieve but were retained by a #40 sieve, and had 99.98 to 99.99 percent purity by weight. Specific heat values below the experimental range were obtained by extrapolation of a Debye equation fitted to the experimental value at the lowest temperature.

Table 4.2
Aluminum Oxide
Specific Heat*

°C	C_p	
	K	J/g°C
-183.15	90	0.0949
-173.15	100	0.1261
-163.15	110	0.1603
-153.15	120	0.1968
-143.15	130	0.2349
-133.15	140	0.2739
-123.15	150	0.3134
-113.15	160	0.3526
-103.15	170	0.3913
-93.15	180	0.4291
-83.15	190	0.4659
-73.15	200	0.5014
-63.15	210	0.5356
-53.15	220	0.5684
-43.15	230	0.5996
-33.15	240	0.6294
-23.15	250	0.6579
-13.15	260	0.6848
-3.15	270	0.7103
0.00	273.15	0.7180
6.85	280	0.7343
16.85	290	0.7572
26.85	300	0.7788
36.85	310	0.7994
46.85	320	0.8188
56.85	330	0.8373
66.85	340	0.8548

*Taken from D.A. Ditmars, *et.als.*,
J. Res. Nat.Bur. Stand., Vol 87, No. 2,
pages 159-163 (1982). This is a public
domain publication.

(table continued)

Table 4.2 (continued)*

°C	<i>C_p</i>	
	K	J/g°C
76.85	350	0.8713
86.85	360	0.8871
96.85	370	0.9020
106.85	380	0.9161
116.85	390	0.9296
126.85	400	0.9423
136.85	410	0.9545
146.85	420	0.9660
156.85	430	0.9770
166.85	440	0.9875
176.85	450	0.9975
186.85	460	1.0070
196.85	470	1.0161
206.85	480	1.0247
216.85	490	1.0330
226.85	500	1.0409
236.85	510	1.0484
246.85	520	1.0557
256.85	530	1.0627
266.85	540	1.0692
276.85	550	1.0756
286.85	560	1.0817
296.85	570	1.0876
306.85	580	1.0932
316.85	590	1.0987
326.85	600	1.1038
336.85	610	1.1089

*Taken from D.A. Ditmars, *et.als.*, J. Res. Nat.Bur. Stand., Vol 87, No. 2, pages 159-163 (1982). This is a public domain publication.

(table continued)

Table 4.2 (continued)*

°C	C_p	
	K	J/g°C
346.85	620	1.1137
356.85	630	1.1183
366.85	640	1.1228
376.85	650	1.1271
386.85	660	1.1313
396.85	670	1.1353
406.85	680	1.1393
416.85	690	1.1431
426.85	700	1.1467
446.85	720	1.1538
466.85	740	1.1604
486.85	760	1.1667
506.85	780	1.1726
526.85	800	1.1783
546.85	820	1.1837
566.85	840	1.1888
586.85	860	1.1937
606.85	880	1.1985
626.85	900	1.2030
646.85	920	1.2074
666.85	940	1.2117
686.85	960	1.2159
706.85	980	1.2198
726.85	1000	1.2237
746.85	1020	1.2275
766.85	1040	1.2312
786.85	1060	1.2348

*Taken from D.A. Ditmars, *et.als.*, J. Res. Nat.Bur. Stand., Vol 87, No. 2, pages 159-163 (1982). This is a public domain publication.

(table continued)

Table 4.2 (continued)*

°C	C_p	
	K	J/g°C
806.85	1080	1.2383
826.85	1100	1.2417
846.85	1120	1.2451
866.85	1140	1.2484
886.85	1160	1.2516
906.85	1180	1.2548
926.85	1200	1.2578
976.85	1250	1.2653
1026.85	1300	1.2724
1076.85	1350	1.2792
1126.85	1400	1.2856
1176.85	1450	1.2917
1226.85	1500	1.2975
1276.85	1550	1.3028
1326.85	1600	1.3079
1376.85	1650	1.3128

*Taken from D.A. Ditmars, *et. als.*, J. Res. Nat.Bur. Stand., Vol 87, No.2, pages 159-163 (1982). This is a public domain publication.

CHAPTER 5: Maintenance and Diagnostics

Overview	5-3
Routine Maintenance	5-4
Inspection	5-4
Cleaning the Instrument Keypad	5-4
Cleaning a Contaminated Cell	5-4
Sample Encapsulating Press	5-7
Diagnosing Power Problems	5-8
Fuses	5-8
Power Failures	5-9
DSC 2010 Test Functions	5-12
2010 Confidence Test	5-12
Replacement Parts	5-13

Maintenance and Diagnostics

Overview

The procedures described in this section are the customer's responsibility. Any further maintenance should be performed by a representative of TA Instruments or other qualified service personnel.



Because of the high voltages in this instrument, untrained personnel must not attempt to test or repair any electrical circuits.

Routine Maintenance

Inspection

Examine the instrument periodically for good condition. Ensure that the furnace area is clean. Any sample spillage or residue should be removed before the next experiment.

Cleaning the Instrument Keypad

You can clean the 2010 instrument keypad as often as you like. The keypad is covered with a silk-screened Mylar* overlay that is reasonably water resistant but not waterproof or resistant to strong solvents or abrasives.

A household liquid glass cleaner and paper towel are best for cleaning the instrument keypad. Wet the towel, not the keypad, with the glass cleaner, and then wipe off the keypad.

Cleaning a Contaminated Cell

A poor baseline is often the sign of a contaminated cell. The cell must be cleaned properly to maintain satisfactory operation. Scraping the contamination off is not recommended because the constantan disc is very thin (about 0.1 mm, or 0.004 inches), and if the disc deforms, the baseline may be affected. Scraping can cause severe damage to the cell if it is not done carefully.

* Mylar is a registered trademark of the DuPont Company.

If your baseline performance begins to deteriorate, try the following recommended cleaning procedure.

Begin cleaning by heating the cell with an air purge to 50°C above your normal upper temperature or 600°C, whichever is lower, without pans or bell jar. Use a heating rate of 20°C per minute. After cool-back to room temperature, lightly brush out the cell with a small fiberglass eraser (included in the DSC accessory kit), run the method again, and compare the baselines. If there is a marked improvement but the baseline is still unacceptable, the contaminant probably oxidized and reduced to an inert ash. Run the method again and check for further improvement. Once the baseline is acceptable, return to normal operation.

If the constantan disc looks clean and is not bent or cracked, but the baseline problem remains, it is probably not due to contamination; the cell may need to be replaced (contact your TA Instruments service representative).

Cleaning DSC Pans

The aluminum, gold, and copper pans and the high pressure capsules provided for use with TA Instruments DSC systems are manufactured to high quality standards, including cleaning to remove contaminants that might be present from the manufacturing process. For most applications, these pans can be used as received; however, if the pans are used for high sensitivity experiments (*e.g.*, oxidative stability), an additional cleaning process is recommended before use. This procedure is taken from

Appendix A of ASTM standard E1858 *Test Method for Oxidative Induction Time of Hydrocarbons by Differential Scanning Calorimeters*.

Follow the steps below to clean the TA Instruments DSC sample pans:

1. Place 200 pans in a 250 mL Erlenmeyer flask that has been fitted with a glass stopper.
2. Add approximately 150 mL of reagent grade xylene (enough to cover the pans).
3. Swirl the flask, containing the pans and xylene, for 0.5 to 2.0 min.
4. Let the flask stand for 1.0 min.
5. Decant the xylene out of the flask.
6. Repeat steps 1 through 5.
7. Add approximately 150 mL of reagent grade acetone after the second xylene wash.
8. Swirl the flask, containing the pans and acetone, for 0.5 to 2.0 min.
9. Let the flask stand for 1.0 min.
10. Decant the acetone out of the flask.
11. Repeat steps 7 through 10.
12. Rotate the flask—so that no pans adhere to the bottom or side of the flask—as you flow nitrogen at 150 to 200 mL/min over the wet pans to drive off the excess solvent. This should take approximately 5 to 6 min.

13. Return the cleaned pans to their storage container and record the date they were cleaned.

Sample Encapsulating Press

The only maintenance needed for the Sample Encapsulating Press is an occasional drop of light machine oil on the cam. Also, make sure the dies are free of material that could scratch their surfaces and impair the seal.

Diagnosing Power Problems

Fuses

The 2010 instrument contains several internal fuses; however, they are not user serviceable. If any of the internal fuses blow, a hazard may exist. Call your TA Instruments service representative.

The only fuses that you *should* service yourself are the external fuses, located on the instrument's rear panel. Both slo-blo type fuses are housed in safety-approved fuse carriers, labeled F1 and F2 (see Figure 5.1).

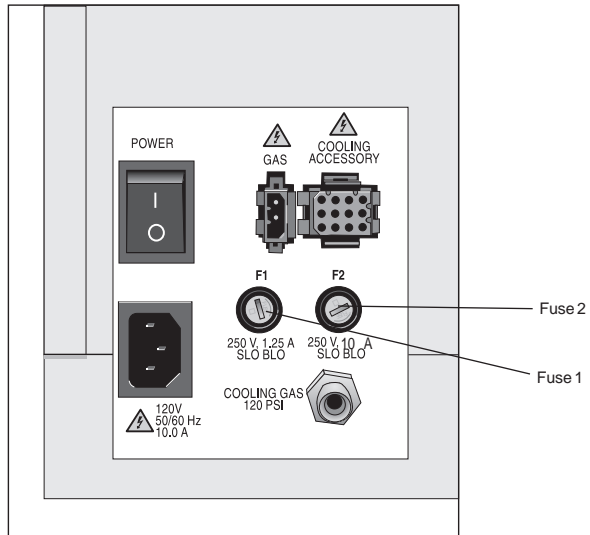

Figure 5.1
Fuse Locations



Always unplug the instrument before you examine or replace the fuses.

Fuse F1 is in the circuit between the main electrical input and the low power loads. All power for internal operations and instrument functions, except heater power and solenoid valves, passes through this fuse. If this fuse blows, you will get no response from the instrument when you attempt to turn it on.

Fuse F2 protects the heater coils in the furnace and supplies power to the optional LNCA. Because fuse F2 does not power the internal logic, you may not know that this fuse is blown until you try to heat a sample; the 2010 passes the confidence test with this fuse open.

Fuse F2 is always checked at the beginning of a method. Power supplied by this circuit is switched by a computer-controlled relay. If fuse F2 is open at the start of a run, then Error 73 “No heater power at method start” is displayed and the run is terminated.

Power Failures

A power failure caused by a temporary drop in line voltage results in one of two responses by the DSC 2010 instrument:

- If the drop is fairly large and of long duration (20 milliseconds or more), the system will reset and go into its power-up sequence when power resumes.
- If the drop is small or of short duration, the system may halt. The instrument will not restart until reset. To reset, press the Reset button on the 2010 instrument back panel.

The 2010 instrument is designed for a nominal line voltage of 115 volts AC ($\pm 10\%$), 50 or 60 Hz. It should not be operated outside this range. Low line voltage may result in poor instrument operation; high line voltage may damage the instrument.

DSC 2010 Test Functions

The DSC 2010 has three levels of test and diagnostic functions:

- The confidence test that is run every time the instrument is started.
- Cycling test functions that continuously test specific.
- A manufacturing verifier test mode that coordinates and logs the results of a sequence of confidence test and drift runs.

These test functions are always present in the instrument. They are designed to aid manufacturing and service in checking and repairing the instrument.

The Confidence Test

Every time the 2010 instrument is powered up or reset, it automatically performs an internal confidence test of the instrument electronics. The confidence test takes approximately 16 seconds to complete. During the confidence test the yellow ready light on the front and rear of the instrument will flash several times, indicating that the test is proceeding normally.

If the confidence test is completed without any fatal errors detected, then the ready light will turn on and remain on steadily, and the instrument will sound a beep. The instrument is now ready to be configured online with the controller.

If a fatal problem is detected during the confidence test, then the ready light will remain off, or continue to flash periodically. The instrument cannot be configured online when fatal errors are detected. Contact your TA Instruments service representative for assistance.

If the confidence test detects a non-fatal problem during start-up, a confidence test error message will be displayed on the controller when the instrument is configured online. Non-fatal error 15, "CMOS RAM checksum error," is displayed immediately after new instrument software is loaded into the 2010 instrument. Resetting the instrument should clear this error. If error 15 persists, or if any other confidence test errors are displayed, contact your TA Instruments service representative for assistance.

Replacement Parts

Table 5.1
List of DSC
2010 Parts

Part Number	Description
900155.000	bell jar, glass dome top for DSC Cell
900681.002	bell jar, glass open top for DSC Cooling Can
900660.903	DSC accessory kit
910824.001	DSC cleaning brush
900639.901	DSC cover
925604.001	DSC 2010 Operator's Manual
983045.901	event cable
205220.021	fuse, 1.25 amp ceramic
205220.040	fuse, 10.00 amp ceramic
202814.339	O-ring, Neoprene, for bell jar
900682.001	O-ring, Silicon, split for DSC Cooling Can
900786.901	pan bottoms, aluminum crimp
900779.901	pan covers, aluminum crimp
253827.000	power cable, 110 V
900635.000	silver lid for DSC, flat with hole
259538.000	stainless steel needle-point tweezer
202515.000	standard, sapphire specific heat
900902.901	standard, vial of indium metal
	<i>(table continued)</i>

Table 5.1
List of DSC
2010 Parts
(continued)

Part Number	Description
993003.001	DSC 2010/TGA 2050 Service Manual
900578.901	Sample pans, platinum
900786.901	Sample pans, aluminum
900779.901	Sample pan lids, aluminum
900793.901	Sample pans, aluminum, hermetic
900794.901	Sample pan lids, alumi- num, hermetic
900860.901	Sample pan lids, alumi- num, hermetic with pin hold
900796.901	Sample pans, coated aluminum, hermetic
900790.901	Sample pan lids, coated aluminum, hermetic
900870.901	Sample pans, aluminum, for SFI samples
900866.901	Sample pans, gold
900868.901	Sample pan lids, gold
900871.901	Sample pans, gold, hermetic
900872.901	Sample pan lids, gold, hermetic
900867.901	Sample pans, copper
900869.901	Sample pan lids, copper
900874.901	Sample pans, graphite
900873.901	Sample pan lids, graphite

Appendix A: The Sample Encapsulating Press

Introduction

The Sample Encapsulating Press is used to seal samples in hermetic and nonhermetic sample pans. Two dies come with the press: one for hermetic sealing and one for nonhermetic sealing. This appendix explains how to change these dies.

Instructions for sealing samples with the Sample Encapsulating Press are given in Chapter 3 of this manual.

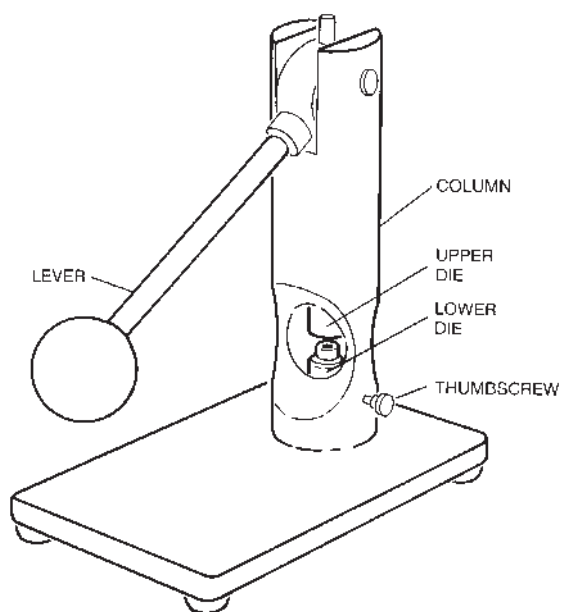

Figure A.1
Sample Encapsulating Press
With Nonhermetic Dies Installed

A:38354 64

Setting Up the Press for Nonhermetic Sealing

The Sample Encapsulating Press is shipped with the upper nonhermetic die installed. To set up the press to make nonhermetic sample pans (when the die is set up for hermetic pans), proceed as follows:

1. Remove the hermetic die set:
 - a. Loosen the thumbscrew on the column of the Sample Press (see Figure A.1).
 - b. Lower the lower die holder by turning the base screw on the bottom of the press counterclockwise.

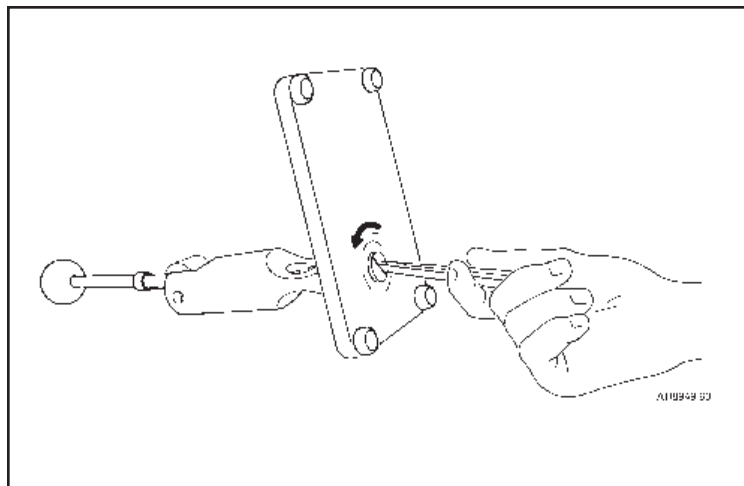

Figure A.2
Lowering the Base Screw

- c. Lift the lower hermetic die and remove it from the die holder.

2. Place the lower nonhermetic die (Figure A.3) into the lower die holder (large end up).

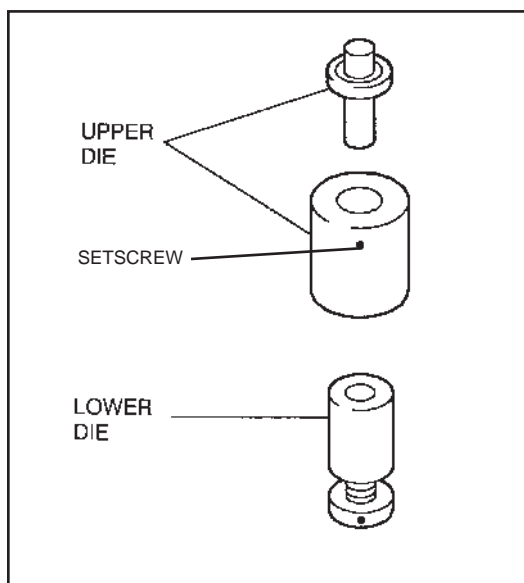

Figure A.3
The Nonhermetic Dies

3. Place the upper nonhermetic die around the plunger of the upper hermetic die (visible when the lever is lowered).
4. Push the upper nonhermetic die upward against the spring-loaded plunger and lock it in place by tightening the setscrew (Figure A.4) with a 0.050" hex wrench.

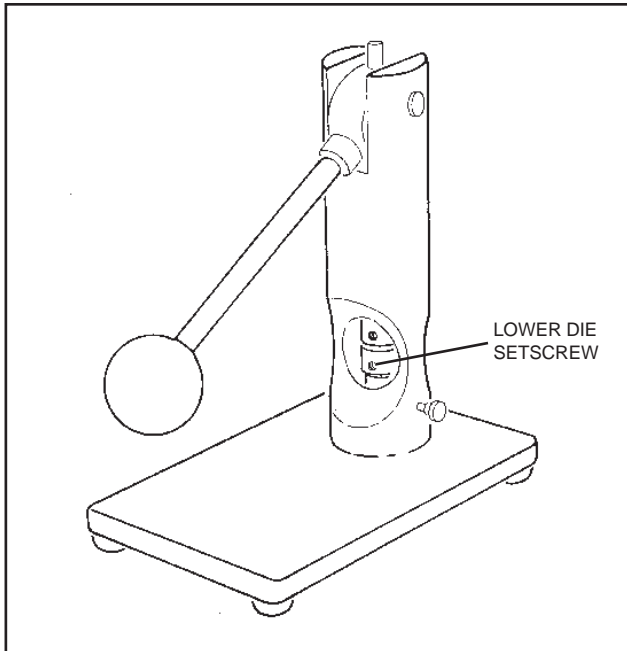
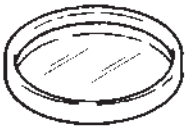
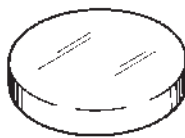
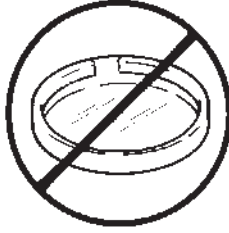

Figure A.4
Lower Die Setscrew

5. Adjust the height of the upper and lower dies:
 - a. Pull the Sample Press lever all the way down (until it rests on the column).
 - b. Turn the screw on the underside of the press clockwise as far as it will go. Then turn the screw back about $\frac{1}{4}$ turn and tighten the lower die holder thumb-screw to lock the lower die holder in place. When the press is adjusted properly, the upper and lower dies just touch. The height of the bottom die may need adjusting based on the sample height.

- c. Make a few sample pans (see Chapter 3) to check the die setting. A good nonhermetic pan will have a flat bottom, and the sides of the pan will appear rolled down (see Table A.1).

Table A.1
Specifications for
Nonhermetic Pans

Uniform folding of lid around circumference	
Flat surface on the bottom of the pan; no ridge around circumference	
No visible gaps between lid and pan	

Setting Up the Press for Hermetic Pans

1. Remove the nonhermetic die set:
 - a. Lower the lever until you can see the setscrew on the upper nonhermetic die. If necessary, turn the upper die to access the lower die setscrew. Loosen the setscrew (Figure A.4) with a 0.050" hex wrench, raise the lever, and remove the upper die.
 - b. Loosen the thumbscrew on the column of the Sample Press (see Figure A.1).
 - c. Lift the lower nonhermetic die and remove it from the die holder.
2. Place the lower hermetic die (Figure A.5) into the lower die holder, either end up.

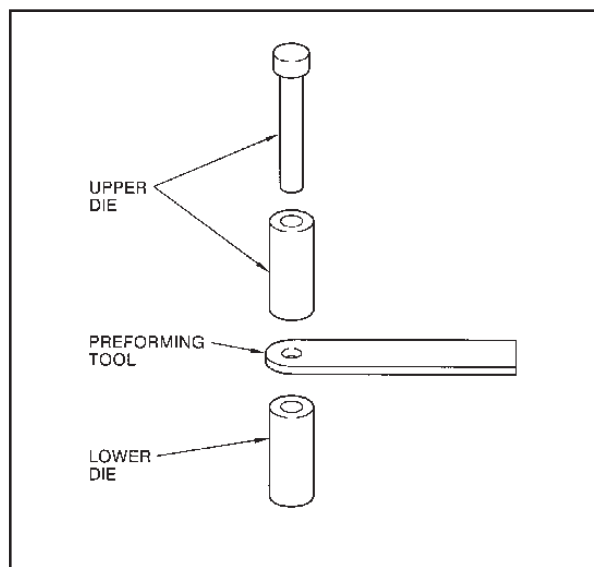

Figure A.5
The Hermetic Dies

3. Check the spring tension of the upper hermetic die (this is the die that remains in the press when the nonhermetic die is removed) by pushing up on the center plunger. If the plunger does not move, adjust the spring tension as follows:
 - a. Lower the Sample Press lever. Raise the lower die holder until it contacts the upper die holder, then unscrew the holder $\frac{1}{4}$ turn. (Loosen the thumb-screw before unscrewing the lower die holder.)
 - b. Keep the lever down and unscrew the upper die setscrew, letting the die come in contact with the lower die. (The upper die is spring loaded and will snap down to contact the lower die.)
 - c. Tighten the setscrew on the upper die.
 - d. Check the tension again. Continue to adjust until you can move the upper die plunger.
4. Adjust the setting of the upper and lower dies:
 - a. Pull the lever down all the way (until it rests on the column).
 - b. Turn the screw on the underside of the press clockwise as far as it will go. Then turn the screw back about $\frac{1}{4}$ -turn and tighten the lower die holder thumb-screw to lock the lower die holder in place.

- c. Make a few sample pans to check the die setting (see Chapter 3 for instructions). A good hermetic pan will have a flat bottom, with a complete seal around the circumference of the pan, and the sides of the pan will appear flat and smooth (see Figure A.6).

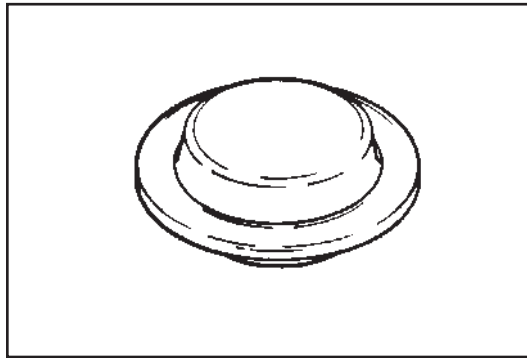

Figure A.6
Properly Sealed
Hermetic Pan

Appendix B: Ordering Information

TA Instruments, Inc.
109 Lukens Drive
New Castle, DE 19720
Telephone: 1-302-427-4000 or 1-302-427-4040
Fax: 1-302-427-4001

HELPLINE—U.S.A.
For technical assistance with current or
potential thermal analysis applications,
please call the Thermal Analysis Help Desk
at 1-302-427-4070.

SERVICE—U.S.A.
For instrument service and repairs,
please call 1-302-427-4050.

TA Instruments Ltd.
Europe House, Bilton Centre
Cleeve Road
Leatherhead, Surrey KT22 7UQ
England
Telephone: 44-1372-360363
Fax: 44-1372-360135

TA Instruments GmbH
Max-Planck-Strasse 11
D-63755 Alzenau
Germany
Telephone: 49-6023-9647-0
Fax: 49-6023-9647-77

TA Instruments Benelux
Ottergemsesteenweg 461
B-9000 Gent
Belgium
Telephone: 32-9-220-79-89
Fax: 32-9-220-83-21

TA Instruments Japan
No. 5 Koike Bldg.
1-3-12 Kitashinagawa
Shinagawa-Ku, Tokyo 140
Japan
Telephone: 813/3450-0981
Fax: 813/3450-1322

TA Instruments France
B.P. 608
78056 Saint-Quentin-Yvelines
Cedex
France
Telephone: 33-1-30-48 94 60
Fax: 33-1-30-48 94 51

TA Instruments Spain
Waters Cromatografía, S.A.
División TA Instruments
Avda. Europa, 21. Pta. Baja
28108 Alcobendas
Madrid, Spain
Telephone: 34-91-661-8448
Fax: 34-91-661-0855

TA Instruments Australia
Unit 3
38-46 South Street
Rydalmere NSW 2116
Australia
Telephone: 61-29-9331-705
Fax: 61-29-8981-455

TA Instruments Italy
Division of Waters SpA
via Achille Grandi 27
20090 Vimodrone (MI), Italy
Telephone: 39-02-27421-1
Fax: 39-02-250-1827

Index

A

accessories 1-6
 Cooling Can 1-13
 LNCA 1-11
 setting up 3-19
 subambient 1-11

address 2-10

applications 4-7

C

cables
 connecting 2-9

cell
 cleaning 5-4
 description 1-9
 unpacking 2-6

cell block
 heating 4-5

cleaning 5-4
 DSC pans 5-5

Complete (status code) 4-9

components 1-5

constantan disc 4-5

Cooling (status code) 4-9

Cooling Can 3-24
 installation 2-17–2-21
 operation 3-25–3-26

D

DSC 2010
 accessories 1-6, 1-10
 applications 4-7
 cleaning 5-4
 pans 5-5
 connecting cables 2-9
 connecting gas lines 2-9
 connector panel 2-10
 cross-section 4-4
 description 1-3
 function 1-4
 inspection 2-7
 keypad 1-7
 lines 2-12
 location of 2-8
 maintenance 5-4
 power cable 2-15
 power problems
 failures 5-7
 fuses 5-6
 power switch 1-9
 repacking 2-6
 replacement parts 5-11
 shutting down 2-21
 specifications 1-14–1-16
 starting 2-20
 unpacking 2-3

E

Equilib (status code) 4-9

experiment

 procedure 3-7–3-26

 running 3-7–3-26

 starting 3-23–3-26

 stopping 3-23

 subambient 3-24

 starting 3-26

F

fuses 5-6

G

gas

 purge 1-15

Gas Line 2-13

gas lines

 connecting 2-9

GPIO Cable

 connecting 2-9

H

Heat Capacity 4-12

Heating (status code) 4-9

hermetic pans

 preparing 3-16

Holding (status code) 4-9

Hot (status code) 4-9

I

Initial (status code) 4-9

Iso (status code) 4-9

K

keypad 1-7

L

lights 2-20–2-21

LNCA 1-11

N

nonhermetic pans

 preparing 3-13

P

power

 problems with fuses 5-6

power cable 2-15

POWER light 2-20

problems

 power problems 5-6

programmed cooling 3-26

purge gases 1-15

Purge Line 2-12

R

READY light 2-20, 5-10

routine maintenance 5-4

S

sample

characteristics 3-9

encapsulating 3-12

Sample Encapsulating Press
maintenance 5-5

sample pans

hermetic 3-11

nonhermetic 3-11

open 3-12

sample size 3-8

samples

preparing 3-8

types 4-7

shutting down 2-21

specifications 1-14

Stand by (status code) 4-11

Start Up

of DSC 2010 2-20

Status Codes. *See also* name of
status code

list of 4-8

subambient operation

Cooling Can installation 2-17

installations for 2-16

system

turning off 2-21

T

Temp (status code) 4-11

thermocouples

description 4-6

U

unpacking 2-3

V

vacuum line 2-13

Index
